

EXPANDED PACKAGE
712-677-2375

TMS320 FIRST-GENERATION DIGITAL SIGNAL PROCESSORS

JANUARY 1987

- 160-ns Instruction Cycle
- 144/256-Word On-Chip Data RAM
- 1.5K/4K-Word On-Chip Program ROM
- 4K-Word On-chip Program EPROM (TMS320E15/E17)
- EPROM Code Protection for Copyright Security
- 4K-Word Total External Memory at Full Speed
- 32-Bit ALU/Accumulator
- 16 x 16-Bit Multiplier with a 32-Bit Product
- 0 to 16-Bit Barrel Shifter
- Eight Input and Eight Output Channels
- Dual-Channel Serial Port (TMS32011/C17/E17)
- 16-Bit Bidirectional Data Bus with 50-Mbps Transfer Rate
- Single 5-V Supply
- Packaging: 40-Pin DIP and 44-Pin PLCC
- Commercial and Military Versions Available
- NMOS Technology:
 - TMS32010-25 160-ns cycle time
 - TMS32010 200-ns cycle time
 - TMS32010-14 280-ns cycle time
 - TMS32011 200-ns cycle time

TMS32010, TMS320C10
N PACKAGE
(TOP VIEW)

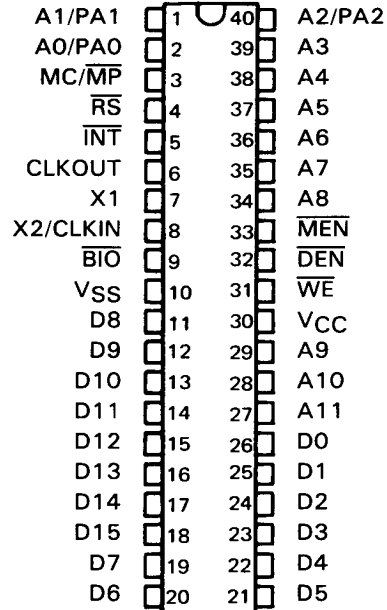

- CMOS Technology:
 - TMS320C10-25 160-ns cycle time
 - TMS320C10 200-ns cycle time
 - TMS320C15-25 160-ns cycle time
 - TMS320C15 200-ns cycle time
 - TMS320E15 (EPROM) . 200-ns cycle time
 - TMS320C17-25 160-ns cycle time
 - TMS320C17 200-ns cycle time
 - TMS320E17 (EPROM) . 200-ns cycle time

This data sheet provides complete design documentation for all the first-generation devices of the TMS320 family. This facilitates the selection of the devices best suited for user applications by providing all specifications and special features for each TMS320 member. This data sheet is divided into four major sections: architecture, electrical specifications (NMOS and CMOS), timing diagrams, and mechanical data. In each of these sections, generic information is presented first, followed by specific device information. An index is provided for quick reference to specific information about a device.

description

The TMS320 family of 16/32-bit single-chip digital signal processors combines the flexibility of a high-speed controller with the numerical capability of an array processor, thereby offering an inexpensive alternative to multichip bit-slice processors. The highly paralleled architecture and efficient instruction set provide speed and flexibility to produce a MOS microprocessor family capable of executing 6.4 MIPS (million instructions per second). The TMS320 family optimizes speed by implementing functions in hardware that other processors implement through microcode or software. This hardware-intensive approach provides the design engineer with processing power previously unavailable on a single chip.

S-190 RES Orig
002413

This document contains information on products in more than one phase of development. The status of each device is indicated on the page(s) specifying its electrical characteristics.



T2413

TF 1

POST OFFICE BOX 1443 • HOUSTON, TEXAS 77001

TMS320 FIRST-GENERATION DEVICES

description (continued)

The TMS320 family consists of two generations of digital signal processors. The first generation contains the TMS32010 and its spinoffs, as described in this data sheet. The TMS32020 and TMS320C25 are the second-generation processors, designed for higher performance. Many features are common among the TMS320 processors. Specific features are added in each processor to provide different cost/performance tradeoffs. Software compatibility is maintained throughout the family to protect the user's investment in architecture. Each processor has software and hardware tools to facilitate rapid design.

introduction

The TMS32010, the first NMOS digital signal processor in the TMS320 family, was introduced in 1983. Its powerful instruction set, inherent flexibility, high-speed number-crunching capabilities, and innovative architecture have made this high-performance, cost-effective processor the ideal solution to many telecommunications, computer, commercial, industrial, and military applications. Since that time, the TMS320C10, a low-power CMOS version of the industry-standard TMS32010, and other spinoff devices have been added to the first generation of the TMS320 family.

The TMS32010 microprocessor is available in three speed versions: TMS32010 (20 MHz), TMS32010-25 (25 MHz), and TMS32010-14 (14 MHz). These devices are capable of executing a 16 x 16-bit multiply with a 32-bit result in a single instruction cycle. On-chip data RAM of 144 words and on-chip program ROM of 1.5K words are available. Full-speed execution of 4K words of off-chip program memory is also possible. The TMS32010-25, a 160-ns instruction cycle time version of the TMS32010, is intended for higher-performance applications that use off-chip program memory and require faster processor throughput (6.25 MIPS). The TMS32010-14 provides a low-cost alternative for DSP applications not requiring the maximum operating frequency of the TMS32010. The device provides a direct EPROM interface for cost-effective system development and modification. All of these devices are pin-for-pin and object-code compatible with the TMS32010 and its development tools.

The TMS32011 is a dedicated microcomputer with 1.5K words of on-chip program ROM intended for high-volume applications. The device is object-code compatible with the TMS32010, and includes a dual-channel serial interface, on-chip μ -law/A-law companding hardware, serial port timer, and peripheral mode for prototyping.

The TMS320C10 is object-code and pin-for-pin compatible with the TMS32010. It is processed in CMOS technology, achieving a power dissipation less than one-sixth that of the NMOS device. The lower power dissipation makes the TMS320C10 ideal for power-sensitive applications such as digital telephony and portable products. The TMS320C10-25, a 25-MHz version of the TMS320C10, has a 160-ns instruction cycle time and is well suited for high-performance DSP applications.

The TMS320C15 and TMS320E15 CMOS devices are object-code and pin-for-pin compatible with the TMS32010 and offer expanded on-chip RAM of 256 words and on-chip program ROM or EPROM of 4K words. These devices allow the capability of upgrading performance and reducing power, board space, and system cost without hardware redesign. The TMS320C15 is also available in a 160-ns version, the TMS320C15-25.

introduction (continued)

The TMS320C17 and TMS320E17 dedicated microcomputers also offer expanded on-chip RAM of 256 words and on-chip program ROM or EPROM of 4K words. These devices provide a dual-channel serial interface, on-chip μ -law/A-law companding hardware, and a serial port timer. In addition, a 16-bit coprocessor interface provides a direct communication channel to common 4/8-bit microcomputers (no glue logic required), and minimal logic interface to most common 16/32-bit microprocessors. The devices are object-code compatible with the TMS32010, pin-for-pin compatible with the TMS32011, and processed in CMOS technology. The TMS320C17 is also available in a 160-ns version, the TMS320C17-25.

Table 1 provides an overview of the first generation of TMS320 processors with comparisons of memory, I/O, cycle timing, power, package type, technology, and military support. For specific availability, contact the nearest TI sales office.

TABLE 1. TMS320 FIRST-GENERATION DEVICE OVERVIEW

DEVICE		MEMORY				I/O†			CYCLE TIME (ns)	TYP POWER (mW)	PACKAGE TYPE	
		ON-CHIP			OFF-CHIP	SER	PAR	CPX			DIP	PLCC
		RAM	ROM	EPROM	EXPANSION							
TMS32010-25	(NMOS)	144	1.5K	—	4K	—	8 x 16	—	160	900	40	—
TMS32010‡	(NMOS)	144	1.5K	—	4K	—	8 x 16	—	200	900	40	—
TMS32010-14	(NMOS)	144	1.5K	—	4K	—	8 x 16	—	280	900	40	—
TMS32011	(NMOS)	144	1.5K	—	—	2	6 x 16	—	200	900	40	—
TMS320C10-25	(CMOS)	144	1.5K	—	4K	—	8 x 16	—	160	200	40	44
TMS320C10§	(CMOS)	144	1.5K	—	4K	—	8 x 16	—	200	165	40	44
TMS320C15-25	(CMOS)	256	4K	—	4K	—	8 x 16	—	160	250	40	44
TMS320C15§	(CMOS)	256	4K	—	4K	—	8 x 16	—	200	225	40	44
TMS320E15§	(CMOS)	256	—	4K	4K	—	8 x 16	—	200	300	40	—
TMS320C17-25	(CMOS)	256	4K	—	—	2	6 x 16	YES	160	275	40	44
TMS320C17	(CMOS)	256	4K	—	—	2	6 x 16	YES	200	250	40	44
TMS320E17	(CMOS)	256	—	4K	—	2	6 x 16	YES	200	325	40	—

†SER = serial; PAR = parallel; CPX = coprocessor interface.

‡Military version available.

§Military version planned; contact nearest TI sales office for availability.

TMS320 FIRST-GENERATION DEVICES

Key Features: TMS32010/C10

- Instruction Cycle Timing:
 - 160 ns (TMS32010-25/C10-25)
 - 200 ns (TMS32010/C10)
 - 280 ns (TMS32010-14)
- 144 Words of On-Chip Data RAM
- 1.5K Words of On-Chip Program ROM
- External Memory Expansion up to 4K Words at Full Speed
- 16 x 16-Bit Multiplier with 32-Bit Product
- 0 to 16-Bit Barrel Shifter
- On-Chip Clock Oscillator
- Single 5-V Supply
- Device Packaging:
 - 40-Pin DIP (all devices)
 - 44-Lead PLCC (CMOS only)
- Technology
 - NMOS: TMS32010/10-14/10-25
 - CMOS: TMS320C10/C10-25

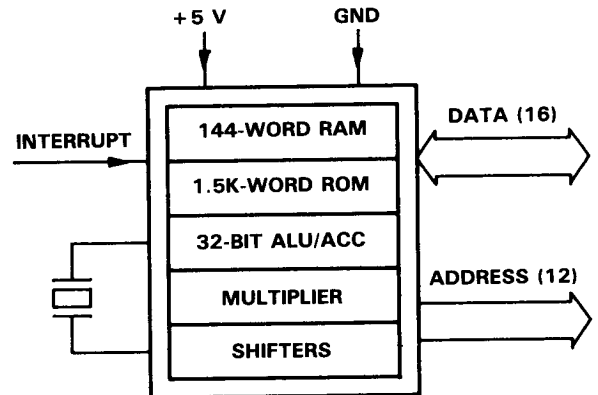

Key Features: TMS320C15/E15

- Instruction Cycle Timing:
 - 160 ns (TMS320C15-25)
 - 200 ns (TMS320C15/E15)
- 256 Words of On-Chip Data RAM
- 4K Words of On-Chip Program ROM (TMS320C15/C15-25)
- 4K Words of On-Chip Program EPROM (TMS320E15)
- EPROM Code Protection for Copyright Security
- External Memory up to 4K Words at Full Speed
- Object-Code and Pin-For-Pin Compatible with TMS32010
- 16 x 16-Bit Multiplier with 32-Bit Product
- 0 to 16-Bit Barrel Shifter
- On-Chip Clock Oscillator
- Single 5-V Supply
- Device Packaging:
 - 40-Pin DIP (all devices)
 - 44-Lead PLCC† (TMS320C15/C15-25)
- CMOS Technology

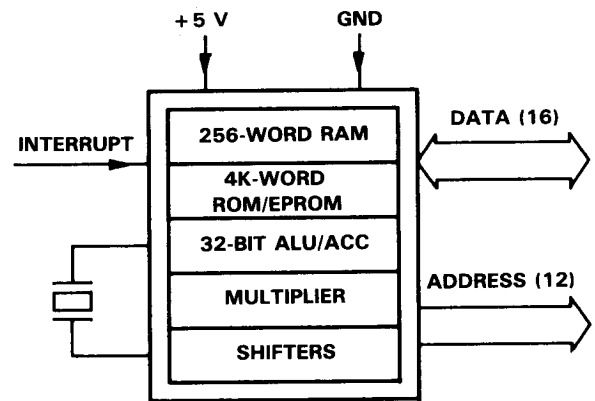

†PLCC version planned, contact nearest TI sales office for availability.

Key Features: TMS32011

- 200-ns Instruction Cycle Timing
- 144 Words of On-Chip Data RAM
- 1.5K Words of On-Chip Program ROM
- Object-Code Compatible with TMS32010
- Dual-Channel Serial Port for Full-Duplex Serial Communication
- Serial Port Timer for Standalone Serial Communications
- On-Chip Companding Hardware for μ -law/A-law PCM Conversions
- Peripheral Mode to TMS32010 for Application Development
- 40-Pin DIP
- NMOS Technology

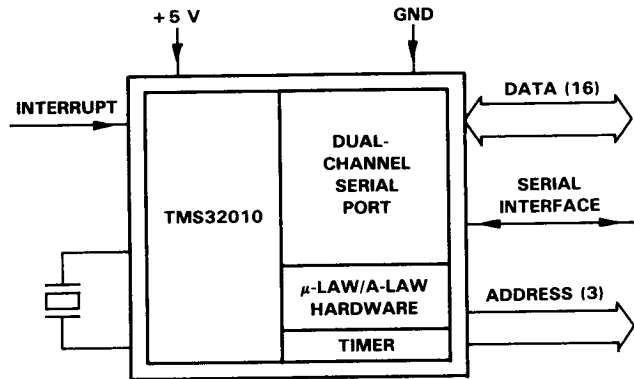

Key Features: TMS320C17/E17

- Instruction Cycle Timing:
 - 160 ns (TMS320C17-25)
 - 200 ns (TMS320C17/E17)
- 256 Words of On-Chip Data RAM
- 4K Words of On-Chip Program ROM (TMS320C17/C17-25)
- 4K Words of On-Chip Program EPROM (TMS320E17)
- EPROM Code Protection for Copyright Security
- Object-Code Compatible with TMS32010
- Pin-For-Pin Compatible with TMS32011
- Dual-Channel Serial Port for Full-Duplex Serial Communication
- Serial Port Timer for Standalone Serial Communications
- On-Chip Companding Hardware for μ -law/A-law PCM Conversions
- 16-Bit Coprocessor Interface for Common 4/8/16/32-Bit Microcomputers/Microprocessors
- Device Packaging:
 - 40-Pin DIP (all devices)
 - 44-Lead PLCC[†] (TMS320C17/C17-25)
- CMOS Technology

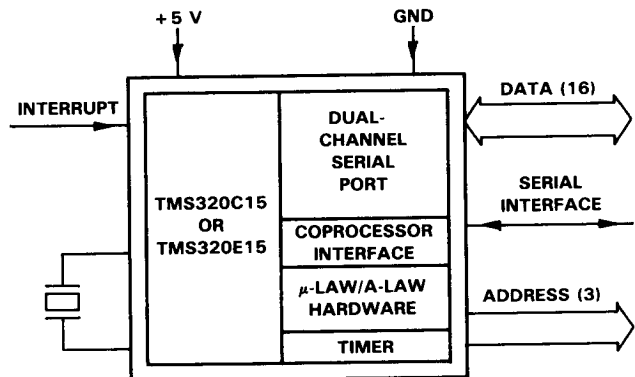

[†]PLCC version planned; contact nearest TI sales office for availability.

architecture

The TMS320 family utilizes a modified Harvard architecture for speed and flexibility. In a strict Harvard architecture, program and data memory lie in two separate spaces, permitting a full overlap of instruction fetch and execution. The TMS320 family's modification of the Harvard architecture allows transfers between program and data spaces, thereby increasing the flexibility of the device. This modification permits coefficients stored in program memory to be read into the RAM, eliminating the need for a separate coefficient ROM. It also makes available immediate instructions and subroutines based on computed values.

32-bit ALU/accumulator

The TMS320 first-generation devices contain a 32-bit ALU and accumulator for support of double-precision, two's-complement arithmetic. The ALU is a general-purpose arithmetic unit that operates on 16-bit words taken from the data RAM or derived from immediate instructions. In addition to the usual arithmetic instructions, the ALU can perform Boolean operations, providing the bit manipulation ability required of a high-speed controller. The accumulator stores the output from the ALU and is often an input to the ALU. It operates with a 32-bit wordlength. The accumulator is divided into a high-order word (bits 31 through 16) and a low-order word (bits 15 through 0). Instructions are provided for storing the high- and low-order accumulator words in memory.

shifters

Two shifters are available for manipulating data. The ALU barrel shifter performs a left-shift of 0 to 16 places on data memory words loaded into the ALU. This shifter extends the high-order bit of the data word and zero-fills the low-order bits for two's-complement arithmetic. The accumulator parallel shifter performs a left-shift of 0, 1, or 4 places on the entire accumulator and places the resulting high-order accumulator bits into data RAM. Both shifters are useful for scaling and bit extraction.

16 x 16-bit parallel multiplier

The multiplier performs a 16 x 16-bit two's-complement multiplication with a 32-bit result in a single instruction cycle. The multiplier consists of three units: the T Register, P Register, and multiplier array. The 16-bit T Register temporarily stores the multiplicand; the P Register stores the 32-bit product. Multiplier values either come from the data memory or are derived immediately from the MPYK (multiply immediate) instruction word. The fast on-chip multiplier allows the device to perform fundamental operations such as convolution, correlation, and filtering.

data and program memory

Since the TMS320 devices use a Harvard architecture, data and program memory reside in two separate spaces. The first-generation devices have 144 or 256 words of on-chip data RAM and 1.5K or 4K words of on-chip program ROM. On-chip program EPROM of 4K words is provided on the TMS320E15/E17. The EPROM cell utilizes standard PROM programmers and is programmed identically to a 64K CMOS EPROM (TMS27C64).

program memory expansion

The first-generation devices are capable of executing up to 4K words of external memory at full speed for those applications requiring external program memory space. This allows for external RAM-based systems to provide multiple functionality. The TMS32011 and TMS320C17/E17 provide no memory expansion capability.

microcomputer/microprocessor operating modes (TMS32010/C10/C15)

The TMS32010/C10 and TMS320C15 devices offer two modes of operation defined by the state of the MC/ $\overline{\text{MP}}$ pin: the microcomputer mode (MC/ $\overline{\text{MP}}$ = 1) or the microprocessor mode (MC/ $\overline{\text{MP}}$ = 0). In the microcomputer mode, on-chip ROM is mapped into the memory space with up to 4K words of memory available. In the microprocessor mode, all 4K words of memory are external.

interrupts and subroutines

The TMS320 first-generation devices contain a four-level hardware stack for saving the contents of the program counter during interrupts and subroutine calls. Instructions are available for saving the device's complete context. PUSH and POP instructions permit a level of nesting restricted only by the amount of available RAM. The interrupts used in these devices are maskable.

input/output

The 16-bit parallel data bus can be utilized to perform I/O functions in two cycles. The I/O ports are addressed by the three LSBs on the address lines. In addition, a polling input for bit test and jump operations ($\overline{\text{BIO}}$) and an interrupt pin (INT) have been incorporated for multitasking.

serial port (TMS32011 and TMS320C17/E17)

Two of the I/O ports on the TMS32011 and TMS320C17/E17 are dedicated to the serial port and companding hardware. I/O port 0 is dedicated to control register 0, which controls the serial port, interrupts, and companding hardware. I/O port 1 accesses control register 1, as well as both serial port channels, and the companding hardware. The six remaining I/O ports are available for external parallel interfaces.

The dual-channel serial port is capable of full-duplex serial communication and offers direct interface to combo-codecs. Receive and transmit registers that operate with 8-bit data samples are I/O-mapped. Either internal or external framing signals for serial data transfers are selected through the system control register. The serial port clock provides the bit timing for transfers with the serial port, and may be either an input or output. A framing pulse signal provides framing pulses for combo-codec circuits, an 8-kHz sample clock for voice-band systems, or a timer for control applications.

companding hardware (TMS32011 and TMS320C17/E17)

On-chip hardware enables the TMS32011 and TMS320C17/E17 to compand (COMpress/exPAND) data in either μ -law or A-law format. The companding logic operation is configured via the system control register. Data may be companded in either a serial mode for operation on serial port data (converting between sign-magnitude linear and logarithmic PCM) or a parallel mode for computation inside the device. The TMS320C17/E17 allows the hardware companding logic to operate with either sign-magnitude or two's-complement numbers.

coprocessor port (TMS320C17/E17)

The coprocessor port on the TMS320C17/E17 provides a direct connection to most 4/8-bit microcomputers and 16/32-bit microprocessors. The port is accessed through I/O port 5 using IN and OUT instructions. The coprocessor interface allows the device to act as a peripheral (slave) microcomputer to a microprocessor, or as a master to a peripheral microcomputer. In the microcomputer mode, the TMS320C17 is fully compatible with the TMS32011. The 16 data lines are used for the 6 parallel 16-bit I/O ports. In the coprocessor mode, the 16-bit parallel port is reconfigured to operate as a 16-bit latched bus interface. For peripheral transfer, an 8-bit or 16-bit length of the coprocessor port can be selected.

TMS320 FIRST-GENERATION DEVICES

instruction set

A comprehensive instruction set supports both numeric-intensive operations, such as signal processing, and general-purpose operations, such as high-speed control. All of the first-generation devices are object-code compatible and use the same 60 instructions. The instruction set consists primarily of single-cycle single-word instructions, permitting execution rates of more than six million instructions per second. Only infrequently used branch and I/O instructions are multicycle. Instructions that shift data as part of an arithmetic operation execute in a single cycle and are useful for scaling data in parallel with other operations.

Three main addressing modes are available with the instruction set: direct, indirect, and immediate addressing.

direct addressing

In direct addressing, seven bits of the instruction word concatenated with the 1-bit data page pointer form the data memory address. This implements a paging scheme in which the first page contains 128 words, and the second page contains up to 128 words.

indirect addressing

Indirect addressing forms the data memory address from the least-significant eight bits of one of the two auxiliary registers, ARO and AR1. The Auxiliary Register Pointer (ARP) selects the current auxiliary register. The auxiliary registers can be automatically incremented or decremented and the ARP changed in parallel with the execution of any indirect instruction to permit single-cycle manipulation of data tables. Indirect addressing can be used with all instructions requiring data operands, except for the immediate operand instructions.

immediate addressing

Immediate instructions derive data from part of the instruction word rather than from the data RAM. Some useful immediate instructions are multiply immediate (MPYK), load accumulator immediate (LACK), and load auxiliary register immediate (LARK).

instruction set summary

Table 2 lists the symbols and abbreviations used in Table 3, the instruction set summary. Table 3 contains a short description and the opcode for each TMS320 first-generation instruction. The summary is arranged according to function and alphabetized within each functional group.

TABLE 2. INSTRUCTION SYMBOLS

SYMBOL	MEANING
ACC	Accumulator
D	Data memory address field
I	Addressing mode bit
K	Immediate operand field
PA	3-bit port address field
R	1-bit operand field specifying auxiliary register
S	4-bit left-shift code
X	3-bit accumulator left-shift field

TABLE 3. TMS320 FIRST-GENERATION INSTRUCTION SET SUMMARY

ACCUMULATOR INSTRUCTIONS																				
MNEMONIC	DESCRIPTION	NO. CYCLES	NO. WORDS	OPCODE																
				INSTRUCTION REGISTER																
				15	14	13	12	11	10	9	8	7	6	5	4	3	2	1	0	
ABS	Absolute value of accumulator	1	1	0	1	1	1	1	1	1	1	1	0	0	0	1	0	0	0	
ADD	Add to accumulator with shift	1	1	0	0	0	0	←S→	I	←D→	←D→	←D→	←D→	←D→	←D→	←D→	←D→	←D→	←D→	
ADDH	Add to high-order accumulator bits	1	1	0	1	1	0	0	0	0	0	0	1	←D→	←D→	←D→	←D→	←D→	←D→	
ADDS	Add to accumulator with no sign extension	1	1	0	1	1	0	0	0	0	0	1	1	←D→	←D→	←D→	←D→	←D→	←D→	←D→
AND	AND with accumulator	1	1	0	1	1	1	1	0	0	1	1	←D→	←D→	←D→	←D→	←D→	←D→	←D→	←D→
LAC	Load accumulator with shift	1	1	0	0	1	0	←S→	I	←D→	←D→	←D→	←D→	←D→	←D→	←D→	←D→	←D→	←D→	
LACK	Load accumulator immediate	1	1	0	1	1	1	1	1	1	0	←K→	←D→	←D→	←D→	←D→	←D→	←D→	←D→	←D→
OR	OR with accumulator	1	1	0	1	1	1	1	0	1	0	1	←D→	←D→	←D→	←D→	←D→	←D→	←D→	←D→
SACH	Store high-order accumulator bits with shift	1	1	0	1	0	1	1	←X→	I	←D→	←D→	←D→	←D→	←D→	←D→	←D→	←D→	←D→	
SACL	Store low-order accumulator bits	1	1	0	1	0	1	0	0	0	0	0	1	←D→	←D→	←D→	←D→	←D→	←D→	←D→
SUB	Subtract from accumulator with shift	1	1	0	0	0	1	←S→	I	←D→	←D→	←D→	←D→	←D→	←D→	←D→	←D→	←D→	←D→	
SUBC	Conditional subtract (for divide)	1	1	0	1	1	0	0	1	0	0	1	←D→	←D→	←D→	←D→	←D→	←D→	←D→	←D→
SUBH	Subtract from high-order accumulator bits	1	1	0	1	1	0	0	0	1	0	1	←D→	←D→	←D→	←D→	←D→	←D→	←D→	←D→
SUBS	Subtract from accumulator with no sign extension	1	1	0	1	1	0	0	0	1	1	1	←D→	←D→	←D→	←D→	←D→	←D→	←D→	←D→
XOR	Exclusive OR with accumulator	1	1	0	1	1	1	1	0	0	0	1	←D→	←D→	←D→	←D→	←D→	←D→	←D→	←D→
ZAC	Zero accumulator	1	1	0	1	1	1	1	1	1	1	1	0	0	0	1	0	0	1	
ZALH	Zero accumulator and load high-order bits	1	1	0	1	1	0	0	1	0	1	1	←D→	←D→	←D→	←D→	←D→	←D→	←D→	←D→
ZALS	Zero accumulator and load low-order bits with no sign extension	1	1	0	1	1	0	0	1	1	0	1	←D→	←D→	←D→	←D→	←D→	←D→	←D→	←D→

AUXILIARY REGISTER AND DATA PAGE POINTER INSTRUCTIONS																				
MNEMONIC	DESCRIPTION	NO. CYCLES	NO. WORDS	OPCODE																
				INSTRUCTION REGISTER																
				15	14	13	12	11	10	9	8	7	6	5	4	3	2	1	0	
LAR	Load auxiliary register	1	1	0	0	1	1	1	0	0	R	I	←D→	←D→	←D→	←D→	←D→	←D→	←D→	←D→
LARK	Load auxiliary register immediate	1	1	0	1	1	1	0	0	0	R	←K→	←D→	←D→	←D→	←D→	←D→	←D→	←D→	←D→
LARP	Load auxiliary register pointer immediate	1	1	0	1	1	0	1	0	0	0	1	0	0	0	0	0	0	0	K
LDP	Load data memory page pointer	1	1	0	1	1	0	1	1	1	1	1	←D→	←D→	←D→	←D→	←D→	←D→	←D→	←D→
LDPK	Load data memory page pointer immediate	1	1	0	1	1	0	1	1	1	0	0	0	0	0	0	0	0	0	K
MAR	Modify auxiliary register and pointer	1	1	0	1	1	0	1	0	0	0	1	←D→	←D→	←D→	←D→	←D→	←D→	←D→	←D→
SAR	Store auxiliary register	1	1	0	0	1	1	0	0	0	R	I	←D→	←D→	←D→	←D→	←D→	←D→	←D→	←D→



TMS320 FIRST-GENERATION DEVICES

TABLE 3. TMS320 FIRST-GENERATION INSTRUCTION SET SUMMARY (CONTINUED)

BRANCH INSTRUCTIONS				
MNEMONIC	DESCRIPTION	NO. CYCLES	NO. WORDS	OPCODE
				INSTRUCTION REGISTER
				15 14 13 12 11 10 9 8 7 6 5 4 3 2 1 0
B	Branch unconditionally	2	2	1 1 1 1 1 0 0 1 0 0 0 0 0 0 0 0 0 0 0 0 ← BRANCH ADDRESS →
BANZ	Branch on auxiliary register not zero	2	2	1 1 1 1 0 1 0 0 0 0 0 0 0 0 0 0 0 0 0 0 ← BRANCH ADDRESS →
BGEZ	Branch if accumulator ≥ 0	2	2	1 1 1 1 1 1 0 1 0 0 0 0 0 0 0 0 0 0 0 0 ← BRANCH ADDRESS →
BGZ	Branch if accumulator > 0	2	2	1 1 1 1 1 1 0 0 0 0 0 0 0 0 0 0 0 0 0 0 ← BRANCH ADDRESS →
BIOZ	Branch on $\overline{BIO} = 0$	2	2	1 1 1 1 0 1 1 0 0 0 0 0 0 0 0 0 0 0 0 0 ← BRANCH ADDRESS →
BLEZ	Branch if accumulator ≤ 0	2	2	1 1 1 1 1 0 1 1 0 0 0 0 0 0 0 0 0 0 0 0 ← BRANCH ADDRESS →
BLZ	Branch if accumulator < 0	2	2	1 1 1 1 1 0 1 0 0 0 0 0 0 0 0 0 0 0 0 0 ← BRANCH ADDRESS →
BNZ	Branch if accumulator ≠ 0	2	2	1 1 1 1 1 1 1 0 0 0 0 0 0 0 0 0 0 0 0 0 ← BRANCH ADDRESS →
BV	Branch on overflow	2	2	1 1 1 1 0 1 0 1 0 0 0 0 0 0 0 0 0 0 0 0 ← BRANCH ADDRESS →
BZ	Branch if accumulator = 0	2	2	1 1 1 1 1 1 1 1 0 0 0 0 0 0 0 0 0 0 0 0 ← BRANCH ADDRESS →
CALA	Call subroutine from accumulator	2	1	0 1 1 1 1 1 1 1 1 0 0 0 1 1 0 0
CALL	Call subroutine immediately	2	2	1 1 1 1 1 0 0 0 0 0 0 0 0 0 0 0 0 0 0 0 ← BRANCH ADDRESS →
RET	Return from subroutine or interrupt routine	2	1	0 1 1 1 1 1 1 1 1 0 0 0 1 1 0 1
T REGISTER, P REGISTER, AND MULTIPLY INSTRUCTIONS				
MNEMONIC	DESCRIPTION	NO. CYCLES	NO. WORDS	OPCODE
				INSTRUCTION REGISTER
				15 14 13 12 11 10 9 8 7 6 5 4 3 2 1 0
APAC	Add P register to accumulator	1	1	0 1 1 1 1 1 1 1 1 1 0 0 0 1 1 1 1
LT	Load T register	1	1	0 1 1 0 1 0 1 0 1 0 1 ← D →
LTA	LTA combines LT and APAC into one instruction	1	1	0 1 1 0 1 1 0 0 1 ← D →
LTD	LTD combines LT, APAC, and DMOV into one instruction	1	1	0 1 1 0 1 0 1 1 1 ← D →
MPY	Multiply with T register, store product in P register	1	1	0 1 1 0 1 1 0 1 1 ← D →
MPYK	Multiply T register with immediate operand; store product in P register	1	1	1 0 0 ← K →
PAC	Load accumulator from P register	1	1	0 1 1 1 1 1 1 1 1 1 0 0 0 1 1 1 0
SPAC	Subtract P register from accumulator	1	1	0 1 1 1 1 1 1 1 1 1 0 0 1 0 0 0 0

TABLE 3. TMS320 FIRST-GENERATION INSTRUCTION SET SUMMARY (CONCLUDED)

CONTROL INSTRUCTIONS																			
MNEMONIC	DESCRIPTION	NO. CYCLES	NO. WORDS	OPCODE															
				INSTRUCTION REGISTER															
				15	14	13	12	11	10	9	8	7	6	5	4	3	2	1	0
DINT	Disable interrupt	1	1	0	1	1	1	1	1	1	1	1	0	0	0	0	0	0	1
EINT	Enable interrupt	1	1	0	1	1	1	1	1	1	1	1	0	0	0	0	0	1	0
LST	Load status register	1	1	0	1	1	1	1	0	1	1	1	← D →						
NOP	No operation	1	1	0	1	1	1	1	1	1	1	1	0	0	0	0	0	0	0
POP	POP stack to accumulator	2	1	0	1	1	1	1	1	1	1	1	0	0	1	1	1	0	1
PUSH	PUSH stack from accumulator	2	1	0	1	1	1	1	1	1	1	1	0	0	1	1	1	0	0
ROVM	Reset overflow mode	1	1	0	1	1	1	1	1	1	1	1	0	0	0	1	0	1	0
SOVM	Set overflow mode	1	1	0	1	1	1	1	1	1	1	1	0	0	0	1	0	1	1
SST	Store status register	1	1	0	1	1	1	1	1	0	0	1	← D →						
I/O AND DATA MEMORY OPERATIONS																			
MNEMONIC	DESCRIPTION	NO. CYCLES	NO. WORDS	OPCODE															
				INSTRUCTION REGISTER															
				15	14	13	12	11	10	9	8	7	6	5	4	3	2	1	0
DMOV	Copy contents of data memory location into next higher location	1	1	0	1	1	0	1	0	0	1	1	← D →						
IN	Input data from port	2	1	0	1	0	0	0	← PA →		1	← D →							
OUT	Output data to port	2	1	0	1	0	0	1	← PA →		1	← D →							
TBLR	Table read from program memory to data RAM	3	1	0	1	1	0	0	1	1	1	1	← D →						
TBLW	Table write from data RAM to program memory	3	1	0	1	1	1	1	1	0	1	1	← D →						

development support products

Texas Instruments offers an extensive line of development support products to assist the user in all aspects of TMS320 first-generation-based design and development. These products range from development and application software to complete hardware development and evaluation systems such as the XDS/22. Table 4 lists the development support products for the first-generation TMS320 devices.

System development begins with the use of the Evaluation Module (EVM) or Emulator (XDS). These hardware tools allow the designer to evaluate the processor's performance, benchmark time-critical code, and determine the feasibility of using a TMS320 device to implement a specific algorithm.

Software and hardware can be developed in parallel by using the macro assembler/linker and simulator for software development and the XDS for hardware development. The assembler/linker translates the system's assembly source program into an object module that can be executed by the simulator, XDS, or EVM. The XDS provides realtime in-circuit emulation and is a powerful tool for debugging and integrating software and hardware modules.

Additional support for the TMS320 products consists of extensive documentation and three-day DSP design workshops offered by the TI Regional Technology Centers (RTCs). The workshops provide hands-on experience with the TMS320 development tools. Refer to the *TMS320 Family Development Support Reference Guide* for further information about TMS320 development support products and DSP workshops. When technical questions arise regarding the TMS320, contact the Texas Instruments TMS320 DSP Hotline, (713) TRY A-320.



TABLE 4. TMS320 FIRST-GENERATION SOFTWARE AND HARDWARE SUPPORT

SOFTWARE TOOLS	PART NUMBER
Macro Assembler/Linker	
VAX VMS	TMDS3240210-08
TI/IBM MS/PC-DOS	TMDS3240810-02
Simulator	
VAX VMS	TMDS3240211-08
TI/IBM MS/PC-DOS	TMDS3240811-02
Digital Filter Design Package (DFDP)	
TI PC MS-DOS	DFDP-TI001
IBM PC PC-DOS	DFDP-IBM001
DSP Software Library	
VAX VMS	TMDC3240212-18
TI/IBM MS/PC-DOS	TMDC3240812-12
HARDWARE TOOLS	PART NUMBER
Evaluation Module (EVM)	RTC/EVM320A-03
Analog Interface Board (AIB)	RTC/EVM320C-06
XDS/22 Emulator	TMDS3262211
XDS/22 Upgrade	
Factory Upgrade	TMDS3282215
Customer Upgrade	TMDS3282216
EPROM Programmer Adaptor Socket	RTC/PGM320A-06
TMS320 Design Kit	TMS320DDK

documentation support

Extensive documentation supports the first-generation TMS320 devices from product announcement through applications development. The types of documentation include data sheets with design specifications, complete user's guides, and 750 pages of application reports published in the book *Digital Signal Processing Applications with the TMS320 Family*.

A series of DSP textbooks is being published to support digital signal processing research and education. The first book, *DFT/FFT and Convolution Algorithms*, is now available. The TMS320 newsletter, *Details on Signal Processing*, is published quarterly and distributed to update TMS320 customers on product information. The TMS320 DSP bulletin board service provides access to large amounts of information pertaining to the TMS320 family.

Refer to the *TMS320 Family Development Support Reference Guide* for further information about TMS320 documentation. To receive copies of first-generation TMS320 literature, call the Customer Response Center at 1-800-232-3200.

**TMS32010, TMS32010-25, TMS32010-14
TMS320C10, TMS320C10-25
TMS320C15, TMS320C15-25, TMS320E15**

description

Since the TMS32010 was the first digital signal processor in the TMS320 family, its architecture has served as the basis from which first-generation spinoff devices have evolved. The TMS320C10 is a low-power CMOS version of the TMS32010 and identical to it. The TMS320C15/E15 is object-code and pin-for-pin compatible with the TMS32010 and offers expanded on-chip RAM and ROM or EPROM.

TMS32010, TMS320C10
TMS320C15, TMS320E15
N/JD PACKAGE
(TOP VIEW)

6 Rows

TMS320C10, TMS320C15

FN PACKAGE
(TOP VIEW)

#182

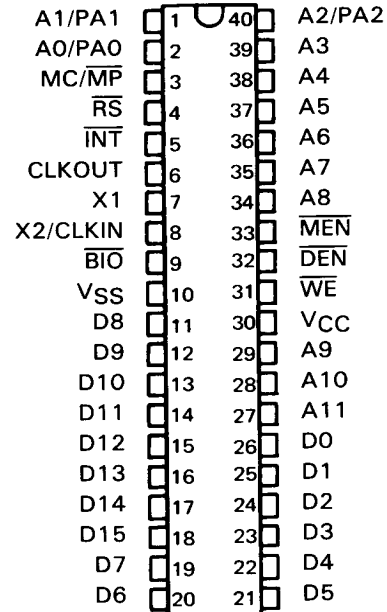
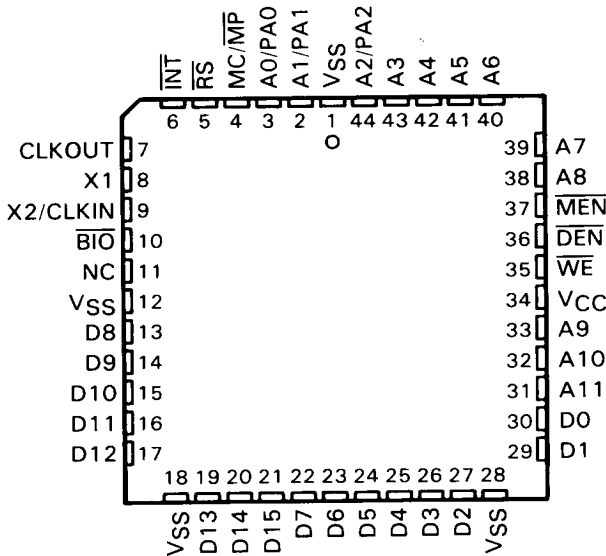

PIN NOMENCLATURE (TMS32010, TMS320C10, TMS320C15, TMS320E15[†])

NAME	I/O/Z [‡]	DEFINITION
A11-A0/PA2-PA0	O	External address bus. I/O port address multiplexed over PA2-PA0.
BIO	I	External polling input
CLKOUT	O	System clock output, 1/4 crystal/CLKIN frequency
D15-D0	I/O/Z	16-bit parallel data bus
DEN	O	Data enable for device input data on D15-D0
INT	I	External interrupt input
MC/MP	I	Memory mode select pin. High selects microcomputer mode. Low selects microprocessor mode.
MEN	O	Memory enable indicates that D15-D0 will accept external memory instruction.
NC	-	No connection; make no external connection to this pin.
RS	I	Reset for initializing the device
VCC	I	+5 V supply
VSS	I	Ground
WE	O	Write enable for device output data on D15-D0
X1	O	Crystal output for internal oscillator
X2/CLKIN	I	Crystal input for internal oscillator or external system clock input

[†]See EPROM programming section.

[‡]Input/Output/High-impedance state.



POST OFFICE BOX 1443 • HOUSTON, TEXAS 77001

**TMS32010, TMS32010-25, TMS32010-14
TMS320C10, TMS320C10-25
TMS320C15, TMS320C15-25, TMS320E15**

functional block diagram (TMS32010, TMS320C10, TMS320C15, TMS320E15)

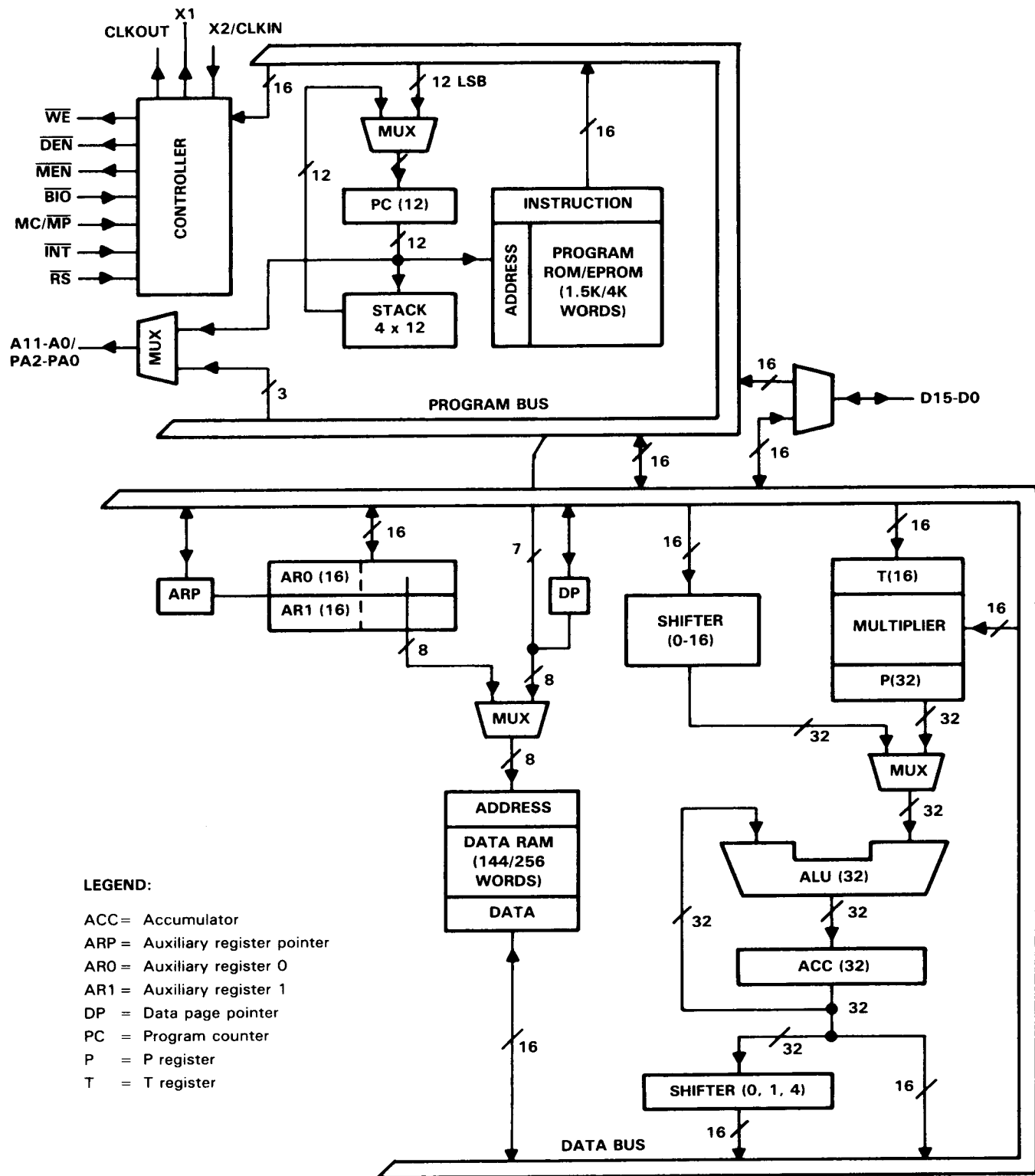

description

The TMS32011 is identical to the TMS32010 microcomputer and fully compatible with the TMS32010 instruction set and development tools. The device features a dual-channel serial port with two transmit and two receive registers for full-duplex communication. The serial port provides a direct interface to combo-codec circuits via three selectable framing pulses and timing logic to support external PCM highway communications and standalone serial applications. On-chip hardware enables the TMS32011 to compand data in either μ -law or A-law conversion format, thus providing increased throughput and reduced ROM space requirements in PCM applications.

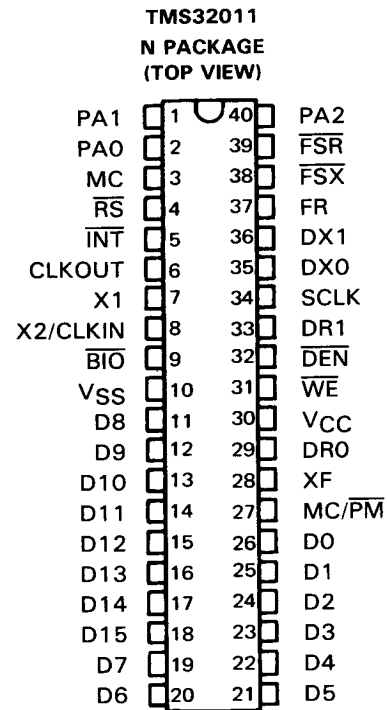

PIN NOMENCLATURE (TMS32011)

NAME	I/O/Z [†]	DEFINITION
BIO	I	External polling input
CLKOUT	O	System clock output, 1/4 crystal/CLKIN frequency
D15-D0	I/O/Z	16-bit parallel data bus
DEN	O	Data enable for device input data on D15-D0
DR1, DR0	I	Serial-port receive-channel inputs
DX1, DX0	O/Z	Serial-port transmit-channel outputs
FR	O	Internal serial-port framing output
FSR	I	External serial-port receive framing input
FSX	I	External serial-port transmit framing input
INT	I	External interrupt input
MC	I	Microcomputer select input, tied to VCC
MC/PM	I	Microcomputer or peripheral mode select input
PA2-PA0	O	I/O port address outputs
RS	I	Reset for initializing the device
SCLK	I/O/Z	Serial-port clock
VCC	I	+5 V supply
VSS	I	Ground
WE	O	Write enable for device output data on D15-D0
X1	O	Crystal output for internal oscillator
X2/CLKIN	I	Crystal input for internal oscillator or external system clock input
XF	O	External-flag output pin

[†]Input/Output/High-impedance state



POST OFFICE BOX 1443 • HOUSTON, TEXAS 77001

functional block diagram (TMS32011)

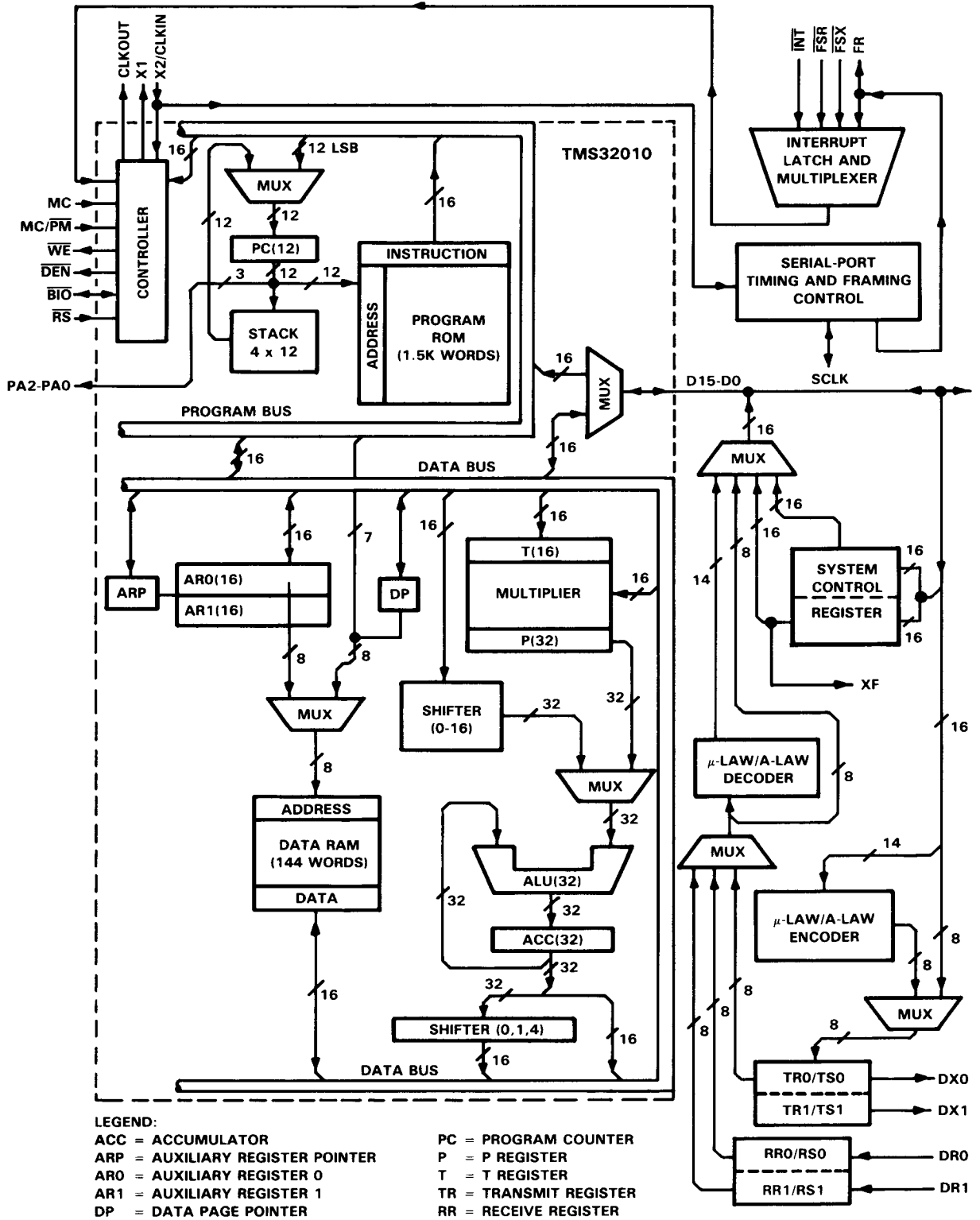

architecture

The TMS32011 consists of four major functional units: the TMS32010 microcomputer, a system control register, a full-duplex dual-channel serial port, and companding hardware.

Two of the I/O ports are dedicated to the serial port and companding hardware, the operation of which is determined by the 32 bits of the system control register (see Table 5 for the control register definitions). Control register 0, accessed through port 0, consists of the lower 16 register bits (CR15-CR0), and is used to control the interrupts, serial port connections, and companding hardware operation. Port 1 accesses control register 1, consisting of the upper 16 control bits (CR31-CR16), as well as both serial port channels and the companding hardware. Communication with the control register is via IN and OUT instructions to ports 0 and 1.

Interrupts have been expanded on the TMS32011 to fully support the serial port interface. Four maskable interrupts ($\overline{\text{INT}}$, FR, $\overline{\text{FSX}}$, and $\overline{\text{FSR}}$) are mapped into I/O port 0 via control register 0. When disabled, these interrupts may be used as single-bit logic inputs polled by software.

serial port

The dual-channel serial port is capable of full-duplex serial communication and offers direct interface to combo-codecs. Two receive and two transmit registers are mapped into I/O port 1, and operate with 8-bit data samples. Internal or external framing signals for serial port transfers (MSB first) are selected via the system control register. The serial port clock, SCLK, provides the bit timing for transfers with the serial port, and may be either an input or output. As an input, an external clock provides the timing for data transfers and framing pulse synchronization. As an output, SCLK provides the timing for standalone serial communication and is derived from the TMS32011 system clock, X2/CLKIN and system control register bits CR27-CR24. See Table 6 for the available divide ratios. The internal framing (FR) pulse frequency is derived from the serial port clock (SCLK) and system control register bits CR23-CR16. This framing pulse signal provides framing pulses for combo-codecs, for a sample clock for voice-band systems, or for a timer used in control applications.

μ -law/A-law companding hardware

On-chip hardware enables the TMS32011 to compand data in either μ -law or A-law format. Data may be companded in either a serial mode for operation on serial port data or a parallel mode for computation inside the device. The companding logic operation is selected through CR14. Note that for μ -law encoding, the bias of 33 must be added to the magnitude before encoding; likewise, after μ -law decoding, the bias of 33 must be subtracted from the magnitude. For A-law companding, no bias is required. For further information on companding, see the *TCM29C13/TCM29C14/TCM29C16/TCM29C17 Combined Single-Chip PCM Codec and Filter Data Sheet*, and the application report, "Companding Routines for the TMS32010/TMS32020," in the book, *Digital Signal Processing Applications with the TMS320 Family*, both documents published by Texas Instruments.

In the serial mode, sign-magnitude linear PCM (13 magnitude bits plus 1 sign bit for μ -law format or 12 magnitude bits plus 1 sign bit for A-law format) is compressed to 8-bit sign-magnitude logarithmic PCM by the encoder and sent to the transmit register for transmission on an active framing pulse. The decoder converts 8-bit sign-magnitude log PCM from the serial port receive registers to sign-magnitude linear PCM.

In the parallel mode, the serial port registers are disabled to allow parallel data from internal memory to be encoded or decoded for computation inside the device. In the parallel encode mode, the encoder is enabled and a 14-bit sign-magnitude value written to port 1. The encoded value is returned with an IN instruction from port 1. In the parallel decode mode, the decoder is enabled and an 8-bit sign-magnitude log PCM value written to port 1. On the successive IN instruction from port 1, the decoded value is returned.

TABLE 5. CONTROL REGISTER CONFIGURATION

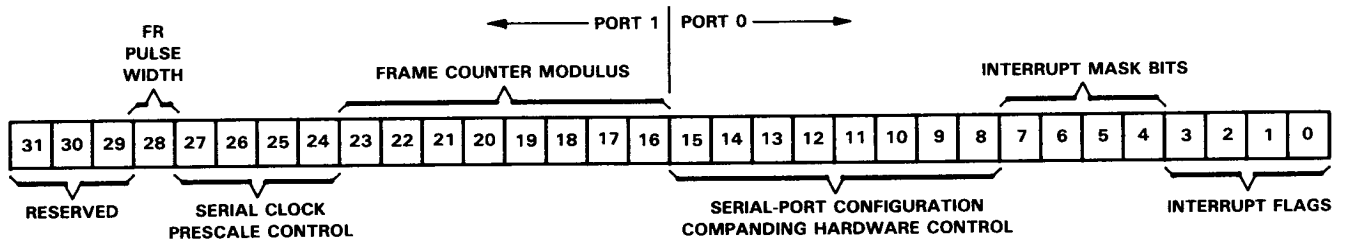

BIT	DESCRIPTION AND CONFIGURATION
0	\overline{INT} interrupt flag [†]
1	\overline{FSR} interrupt flag [†]
2	\overline{FSX} interrupt flag [†]
3	FR interrupt flag [†]
4	\overline{INT} interrupt enable mask. When set to logic 1, an interrupt on \overline{INT} activates device interrupt circuitry.
5	\overline{FSR} interrupt enable mask. Same as \overline{INT} control.
6	\overline{FSX} interrupt enable mask. Same as \overline{INT} control.
7	FR interrupt enable mask. Same as \overline{INT} control.
8	Port 1 configuration control: 0 = port 1 connects to either serial-port registers or companding hardware. 1 = port 1 accesses CR31-CR16.
9	External framing enable: 0 = serial-port data transfers controlled by active FR. 1 = serial-port data transfers controlled by active $\overline{FSX}/\overline{FSR}$.
10	XF external logic output flag latch
11	Serial-port enable: 0 = parallel companding mode; serial port disabled. 1 = serial companding mode; serial port registers enabled.
12	μ -law/A-law encoder enable: 0 = disabled. 1 = data written to port 1 is μ -law or A-law encoded.
13	μ -law/A-law decoder enable: 0 = disabled. 1 = data read from port 1 is μ -law or A-law decoded.
14	μ -law or A-law encode/decode select: 0 = companding hardware performs μ -law conversion. 1 = companding hardware performs A-law conversion.
15	Serial clock control: 0 = SCLK is an output, derived from the prescaler in timing logic. 1 = SCLK is an input that provides the clock for serial port and frame counter in timing logic.
23-16	Frame counter modulus. Controls FR frequency = $SCLK/(CNT + 2)$ where CNT is binary value of CR23-CR16. [‡]
27-24	SCLK prescale control bits. (See Table 6 for divide ratios).
28	FR pulse-width control: 0 = fixed-data rate; FR is 1 SCLK cycle wide. 1 = variable-data rate; FR is 8 SCLK cycles wide.
31-29	Reserved for future expansion. Should be set to 0.

[†] Interrupt flag is cleared by writing a logic 1 to the bit with an OUT instruction to port 0.

[‡] All ones in CR23-CR16 indicate a degenerative state and should be avoided. Bits are operational whether SCLK is an input or an output. CNT must be greater than 7.

TABLE 6. SERIAL CLOCK (SCLK) DIVIDE RATIOS (X2/CLKIN = 20.48 MHZ)

CR27	CR26	CR25	CR24	DIVIDE RATIO	SCLK FREQUENCY	UNIT
0	0	0	0	32	0.640	MHz
0	0	0	1	28	0.731	MHz
0	0	1	X	24	0.853	MHz
0	1	X	X	20	1.024	MHz
1	0	0	0	16	1.280	MHz
1	0	0	1	14	1.463	MHz
1	0	1	X	12	1.706	MHz
1	1	X	X	10	2.048	MHz

 μ -law/A-law companding hardware (continued)

The specification for μ -law and A-law log PCM coding is part of the CCITT G.711 recommendation. Part of the coding format specifies certain bits to be inverted prior to transmission or upon receipt of transmitted data. For the μ -law format, all of the data bits are inverted. However, external inverters are required on serial port data lines DX0, DX1, DR0, and DR1 to provide the bit inversion for the A-law format. The following diagram shows a TMS32011 codec interface circuit as used for the μ -law format, and a circuit with 74ALS04 inverters added to correctly handle the A-law companded PCM data.

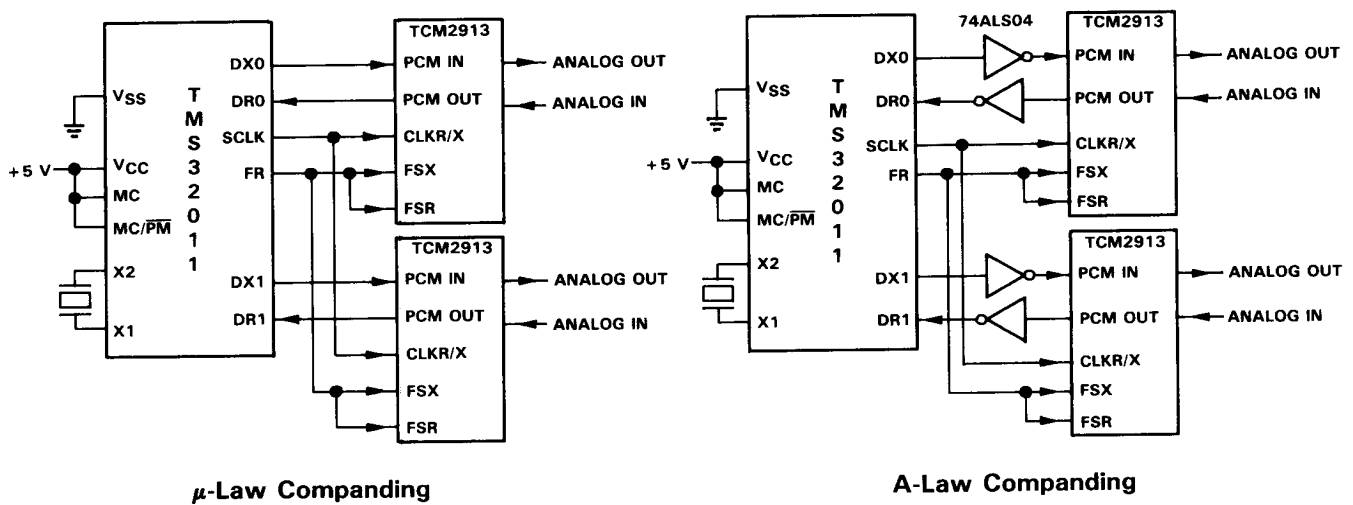

TMS320C17
TMS320C17-25
TMS320E17

description

The TMS320C17, like the TMS320C15, has 256 words of on-chip data RAM and 4K words of on-chip program ROM. The TMS320C17 is object-code compatible with the TMS32010 and pin-for-pin compatible with the TMS32011. The TMS320C17 provides a dual-channel serial port that is fully compatible with the TMS32011 and designed specifically to interface to two combocodes. A 16-bit coprocessor interface is also provided for interfacing to common 4/8/16/32-bit microcomputers/microprocessors.

architecture

The TMS320C17 consists of five major functional units: the TMS320C15 microcomputer, a system control register, a full-duplex dual-channel serial port, companding hardware, and a coprocessor port.

TMS320C17, TMS320E17

N/JD PACKAGE
(TOP VIEW)

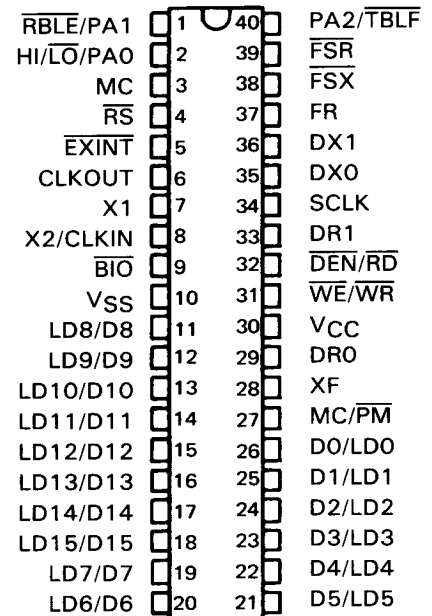

PIN NOMENCLATURE (TMS320C17, TMS320E17†)

NAME	I/O/Z‡	DEFINITION
BIO	I	External polling input
CLKOUT	O	System clock output, ¼ crystal/CLKIN frequency
D15/LD15-DO/LD0	I/O/Z	16-bit parallel data bus/data lines for coprocessor latch
DEN/RD	I/O/Z	Data enable for device input data/external read for output latch
DR1, DRO	I	Serial-port receive-channel inputs
DX1, DX0	O/Z	Serial-port transmit-channel outputs
EXINT	I	External interrupt input
FR	O	Internal serial-port framing output
FSR	I	External serial-port receive framing input
FSX	I	External serial-port transmit framing input
MC	I	Microcomputer select (must be same state as MC/PM)
MC/PM	I	Microcomputer/peripheral coprocessor select (must be same state as MC)
PA0/HI/LO	I/O/Z	I/O port address output/latch byte select pin
PA1/RBLE	O	I/O port address output/receive buffer latch empty flag
PA2/TBLF	O	I/O port address output/transmit buffer latch full flag
RS	I	Reset for initializing the device
SCLK	I/O/Z	Serial-port clock
VCC	I	+ 5 V Supply
VSS	I	Ground
WE/WR	I/O	Write enable for device output data/external write for input latch
X1	O	Crystal output for internal oscillator
X2/CLKIN	I	Crystal input for internal oscillator or external oscillator system clock input
XF	O	External-flag output pin

†See EPROM programming section.
‡Input/Output/High-impedance state.

functional block diagram (TMS320C17, TMS320E17)

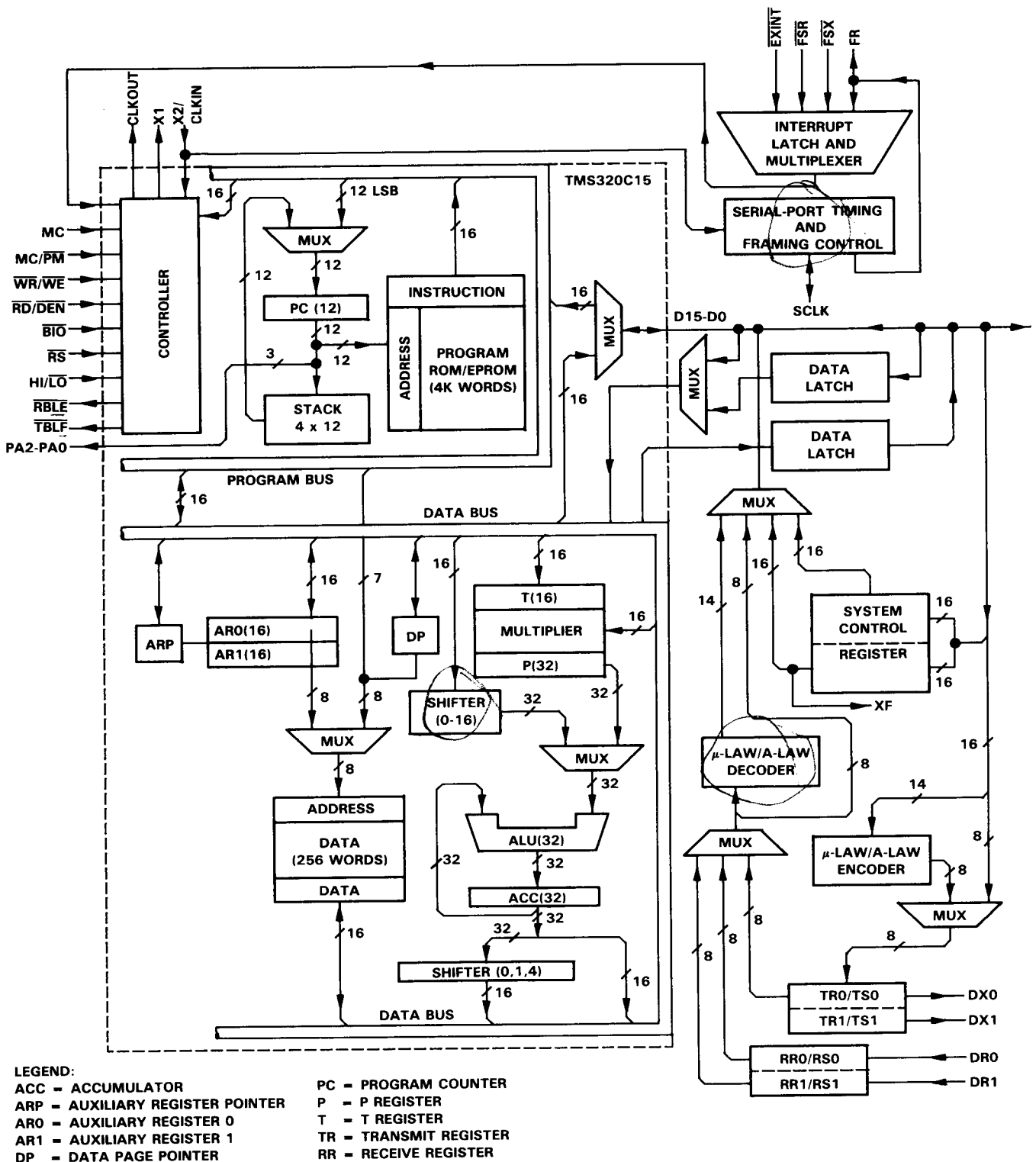

POST OFFICE BOX 1443 • HOUSTON, TEXAS 77001

architecture (continued)

Three of the I/O ports are used by the serial port, companding hardware, and the coprocessor port. Their operation is determined by the 32 bits of the system control register (see Table 7 for the TMS320C17 control register definitions). Control register 0, accessed through port 0, consists of the lower 16 register bits (CR15-CR0), and is used to control the interrupts, serial port connections, and companding hardware operation. Port 1 accesses control register 1, consisting of the upper 16 control bits (CR31-CR16), as well as both serial port channels, the companding hardware, and the coprocessor port channels. Communication with the control register is via IN and OUT instructions to ports 0 and 1.

Interrupts, like on the TMS32011, fully support the TMS320C17 serial port interface. Four maskable interrupts ($\overline{\text{EXINT}}$, $\overline{\text{FR}}$, $\overline{\text{FSX}}$, and $\overline{\text{FSR}}$) are mapped into I/O port 0 via control register 0. When disabled, these interrupts may be used as single-bit logic inputs polled by software.

serial port

The dual-channel serial port is capable of full-duplex serial communication and offers direct interface to two-combo-codecs. Two receive and two transmit registers are mapped into I/O port 1, and operate with 8-bit data samples. Internal and external framing signals for serial port transfers (MSB first) are selected via the system control register. The serial port clock, SCLK, provides the bit timing for transfers with the serial port, and may be either an input or output. As an input, an external clock provides the timing for data transfers and framing pulse synchronization. As an output, SCLK provides the timing for standalone serial communication and is derived from the TMS320C17 system clock, X2/CLKIN and system control register bits CR27-CR24. See Table 6 for the available divide ratios, the same as used with the TMS32011. The internal framing (FR) pulse frequency is derived from the serial port clock (SCLK) and system control register bits CR23-CR16. This framing pulse signal provides framing pulses for combo-codecs, for a sample clock for voice-band systems, or for a timer used in control applications.

μ -law/A-law companding hardware

The TMS320C17 features hardware companding logic that can operate in either μ -law or A-law format with either sign-magnitude or two's-complement numbers. Data may be companded in either a serial mode for operation on serial port data or a parallel mode for computation inside the device. The companding logic operation is selected through CR14. No bias is required when operating in two's complement. A bias of 33 is required for sign magnitude in μ -law companding. Upon reset, the device is programmed to operate in sign-magnitude mode to maintain compatibility with the TMS32011. This mode can be changed by modifying control bit 29 (CR29) in control register 1.

In the serial mode, sign-magnitude linear PCM (13 magnitude bits plus 1 sign bit for μ -law format or 12 magnitude bits plus 1 sign bit for A-law format) is compressed to 8-bit sign-magnitude logarithmic PCM by the encoder and sent to the transmit register for transmission on an active framing pulse. The decoder converts 8-bit sign-magnitude log PCM from the serial port receive registers to sign-magnitude linear PCM.

In the parallel mode, the serial port registers are disabled to allow parallel data from internal memory to be encoded or decoded for computation inside the device. In the parallel encode mode, the encoder is enabled and a 14-bit sign-magnitude value written to port 1. The encoded value is returned with an IN instruction from port 1. In the parallel decode mode, the decoder is enabled and an 8-bit sign-magnitude log PCM value written to port 1. On the successive IN instruction from port 1, the decoded value is returned.

TABLE 7. CONTROL REGISTER CONFIGURATION

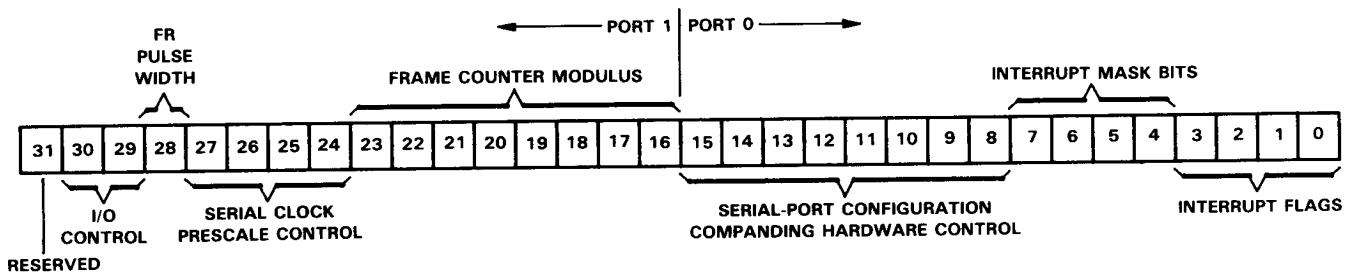

BIT	DESCRIPTION AND CONFIGURATION
0	EXINT̄ interrupt flag [†]
1	FSR̄ interrupt flag [†]
2	FSX̄ interrupt flag [†]
3	FR interrupt flag [†]
4	EXINT̄ interrupt enable mask. When set to logic 1, an interrupt on EXINT̄ activates device interrupt circuitry.
5	FSR̄ interrupt enable mask. Same as EXINT̄ control.
6	FSX̄ interrupt enable mask. Same as EXINT̄ control.
7	FR interrupt enable mask. Same as EXINT̄ control.
8	Port 1 configuration control: 0 = port 1 connects to either serial-port registers or companding hardware. 1 = port 1 accesses CR31-CR16.
9	External framing enable: 0 = serial-port data transfers controlled by active FR. 1 = serial-port data transfers controlled by active FSX̄/FSR̄.
10	XF external logic output flag latch
11	Serial-port enable: 0 = parallel companding mode; serial port disabled. 1 = serial companding mode; serial port registers enabled.
12	μ-law/A-law encoder enable: 0 = disabled. 1 = data written to port 1 is μ-law or A-law encoded.
13	μ-law/A-law decoder enable: 0 = disabled. 1 = data read from port 1 is μ-law or A-law decoded.
14	μ-law or A-law encode/decode select: 0 = companding hardware performs μ-law conversion. 1 = companding hardware performs A-law conversion.
15	Serial clock control: 0 = SCLK is an output, derived from the prescaler in timing logic. 1 = SCLK is an input that provides the clock for serial port and frame counter in timing logic.
23-16	Frame counter modulus. Controls FR frequency = SCLK/(CNT + 2) where CNT is binary value of CR23-CR16. [‡]
27-24	SCLK prescale control bits. (See Table 6 for divide ratios.)
28	FR pulse-width control: 0 = fixed-data rate; FR is 1 SCLK cycle wide. 1 = variable-data rate; FR is 8 SCLK cycles wide.
29	Two's-complement μ-law/A-law conversion enable: 0 = sign-magnitude companding 1 = two's-complement companding
30	8/16-bit length coprocessor mode select: 0 = 8-bit byte length 1 = 16-bit word length
31	Reserved for future expansion. Should be set zero.

[†] Interrupt flag is cleared by writing a logic 1 to the bit with an OUT instruction to port 0.

[‡] All ones in CR23-CR16 indicate a degenerative state and should be avoided. Bits are operational whether SCLK is an input or an output. CNT must be greater than 7.

μ -law/A-law companding hardware (continued)

The following diagram shows a TMS320C17 interface to two codecs as used for μ -law or A-law companding format.

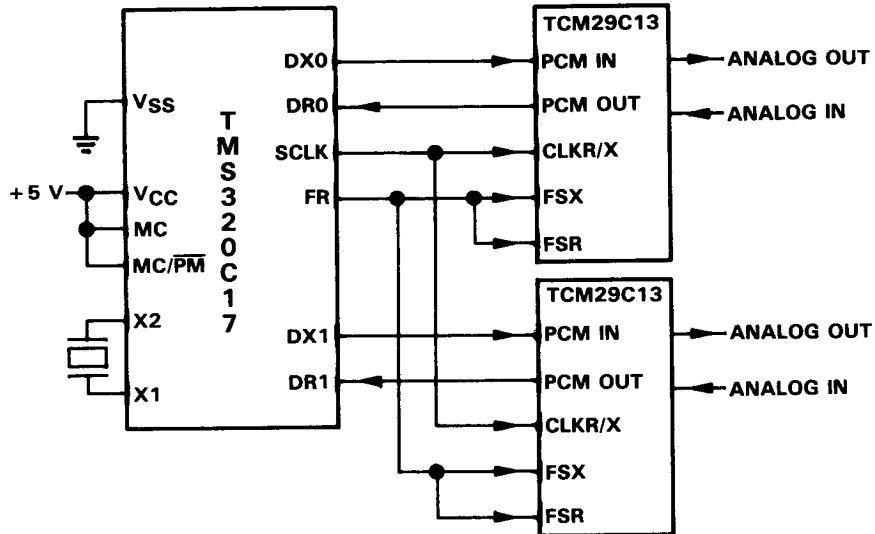

coprocessor port

The coprocessor port, accessed through I/O port 5 using IN and OUT instructions, provides a direct connection to most 4/8-bit microcomputers and 16/32-bit microprocessors. The coprocessor interface allows the TMS320C17 to act as a peripheral (slave) microcomputer to a microprocessor, or a master to a peripheral microcomputer such as TMS7042. The coprocessor port is enabled by setting $\overline{MC/PM}$ and MC low. The microcomputer mode is enabled by setting these two pins high. (Note that $\overline{MC/PM} \neq \overline{MC}$ is undefined.) In the microcomputer mode, the TMS320C17 is fully compatible with the TMS32011. The 16 data lines are used for the 6 parallel 16-bit I/O ports.

In the coprocessor mode, the 16-bit coprocessor port is reconfigured to operate as a 16-bit latched bus interface. Control bit 30 (CR30) in control register 1 is used to configure the coprocessor port to either an 8-bit or a 16-bit length. When CR30 is high, the coprocessor port is 16 bits wide, thereby making all 16 bits of the data port available for 16-bit transfers to 16 and 32-bit microprocessors. When CR30 is low, the port is 8 bits wide and mapped to the low byte of the data port for interfacing to 8-bit microcomputers. When operating in the 8-bit mode, both halves of the 16-bit latch can be addressed using the $\overline{HI/LO}$ pin, thus allowing 16-bit transfers over 8 data lines. When not in the coprocessor mode, port 5 can be used as a generic I/O port.

The external processor recognizes the coprocessor interface, in which both processors run asynchronously, as a memory-mapped I/O operation. The external processor lowers the \overline{WR} line and places data on the bus. It next raises the \overline{WR} line to clock the data into the on-chip latch. The rising edge of \overline{WR} automatically creates an interrupt to the TMS320C17 and the falling edge of \overline{WR} clears the \overline{RBLE} (receive buffer latch empty) flag. Likewise, the external processor reads from the latch by driving the \overline{RD} line active low, thus enabling the output latch to drive the latched data. When the data has been read, the external device will again bring the \overline{RD} line high. This activates the \overline{BIO} line to signal that the transfer is complete and the latch is available for the next transfer. The falling edge of \overline{RD} resets the \overline{TBLF} (transmit buffer latch full) flag. Note that the \overline{EXINT} and \overline{BIO} lines are reserved for coprocessor interface and cannot be driven externally when in the coprocessor mode.

coprocessor port (continued)

An example of the use of a coprocessor interface is shown below, in which the TMS320C17 is interfaced to the TMS70C42, an 8-bit microcontroller.

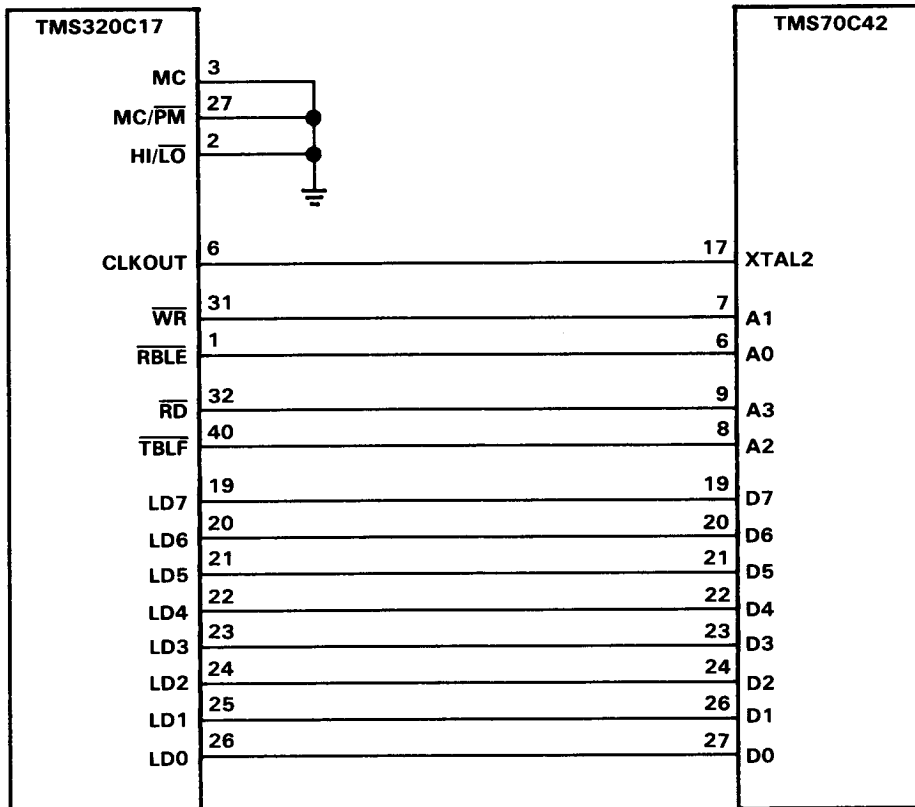



NMOS DEVICE ELECTRICAL SPECIFICATIONS

This section contains all the electrical specifications for the TMS320 NMOS first-generation devices. Refer to the top corner for the specific device.

absolute maximum ratings over specified temperature range (unless otherwise noted)[†]

Supply voltage range, V_{CC}^{\ddagger}	−0.3 V to 7 V
Input voltage range	−0.3 V to 15 V
Output voltage range	−0.3 V to 15 V
Continuous power dissipation	1.5 W
Air temperature range above operating device	0°C to 70°C
Storage temperature range	−55°C to +150°C

[†]Stresses beyond those listed under "Absolute Maximum Ratings" may cause permanent damage to the device. This is a stress rating only and functional operation of the device at these or any other conditions beyond those indicated in the "Recommended Operating Conditions" section of this specification is not implied. Exposure to absolute-maximum-rated conditions for extended periods may affect device reliability.

[‡]All voltage values are with respect to V_{SS} .

recommended operating conditions

		MIN	NOM	MAX	UNIT
V_{CC}	Supply voltage	4.75	5	5.25	V
V_{SS}	Supply voltage		0		V
V_{IH}	High-level input voltage	All inputs except CLKIN		2	V
		CLKIN		2.8	
V_{IL}	Low-level input voltage (all inputs)			0.8	V
I_{OH}	High-level output current (all outputs)			−300	μ A
I_{OL}	Low-level output current (all outputs)			2	mA
T_A	Operating free-air temperature	0		70	°C

electrical characteristics over specified temperature range (unless otherwise noted)

PARAMETER		TEST CONDITIONS		MIN	TYP [†]	MAX	UNIT
V_{OH}	High-level output voltage	$I_{OH} = \text{MAX}$		2.4	3		V
V_{OL}	Low-level output voltage	$I_{OL} = \text{MAX}$			0.3	0.5	V
I_{OZ}	Off-state output current	$V_{CC} = \text{MAX}$	$V_O = 2.4 \text{ V}$			20	μ A
			$V_O = 0.4 \text{ V}$			−20	
I_I	Input current	$V_I = V_{SS} \text{ to } V_{CC}$	All inputs except CLKIN			±20	μ A
			CLKIN			±50	
I_{CC}^{\ddagger}	Supply current	$V_{CC} = \text{MAX}$	$T_A = 0^\circ\text{C}$		180	275	mA
			$T_A = 70^\circ\text{C}$			235 [§]	
C_i	Input capacitance	Data bus	$f = 1 \text{ MHz, All other pins } 0 \text{ V}$			25 [§]	pF
		All others				15 [§]	
C_o	Output capacitance	Data bus				25 [§]	pF
		All others				10 [§]	

[†]All typical values except for I_{CC} are at $V_{CC} = 5 \text{ V, } T_A = 25^\circ\text{C}$.

[‡] I_{CC} characteristics are inversely proportional to temperature; i.e., I_{CC} decreases approximately linearly with temperature.

[§]Value derived from characterization data and not tested.



PARAMETER MEASUREMENT INFORMATION

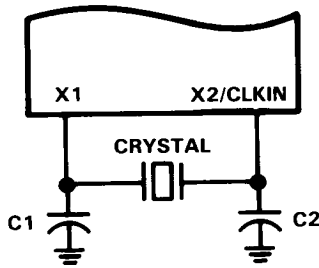

FIGURE 1. INTERNAL CLOCK OPTION

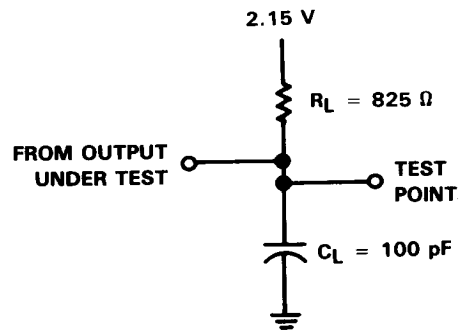

FIGURE 2. TEST LOAD CIRCUIT

input synchronization requirements

For systems using asynchronous inputs to the $\overline{\text{INT}}$ and $\overline{\text{BIO}}$ pins on the TMS32010, the external hardware shown in the diagrams below is recommended to ensure proper execution of interrupts and the BIOZ instruction. This hardware synchronizes the $\overline{\text{INT}}$ and $\overline{\text{BIO}}$ input signals with the rising edge of CLKOUT on the TMS32010. The pulse width required for these input signals is $t_{C(C)}$, which is one TMS32010 clock cycle, plus sufficient setup time for the flip-flop (dependent upon the flip-flop used). Note that these input synchronization requirements apply only to NMOS versions of the TMS32010 and not to other members of the TMS320 family.

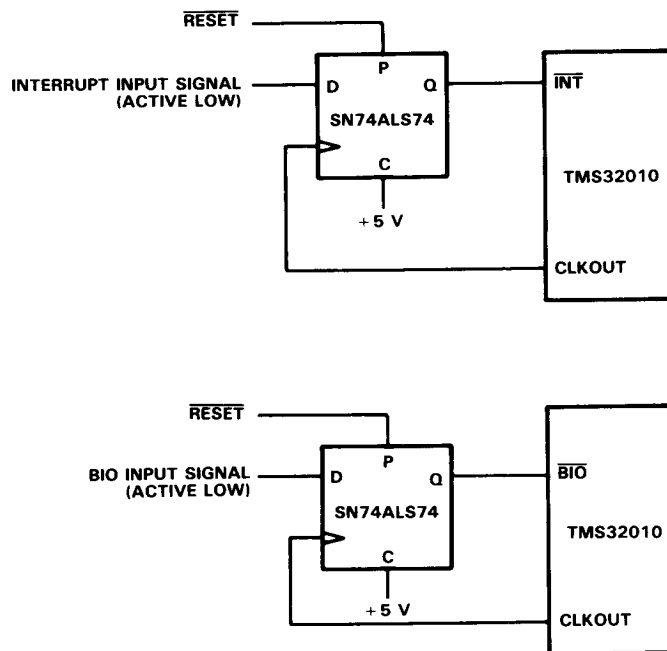

FIGURE 3. ASYNCHRONOUS INPUT SYNCHRONIZATION CIRCUITS

CLOCK CHARACTERISTICS AND TIMING

The TMS32010 can use either its internal oscillator or an external frequency source for a clock.

internal clock option

The internal oscillator is enabled by connecting a crystal across X1 and X2/CLKIN (see Figure 1). The frequency of CLKOUT is one-fourth the crystal fundamental frequency. The crystal should be fundamental mode, and parallel resonant, with an effective series resistance of 30 ohms, a power dissipation of 1 mW, and be specified at a load capacitance of 20 pF.

PARAMETER	TEST CONDITIONS	TMS32010			TMS32010-25			UNIT
		MIN	NOM	MAX	MIN	NOM	MAX	
Crystal frequency f_x	0°C to 70°C	6.7		20.5	6.7		25.0	MHz
C1, C2	0°C to 70°C	10			10			pF

external clock option

An external frequency source can be used by injecting the frequency directly into X2/CLKIN with X1 left unconnected. The external frequency injected must conform to the specifications listed in the table below.

switching characteristics over recommended operating conditions

PARAMETER	TEST CONDITIONS	TMS32010			TMS32010-25			UNIT
		MIN	NOM	MAX	MIN	NOM	MAX	
$t_c(C)$ CLKOUT cycle time [†]	$R_L = 825 \Omega$, $C_L = 100 \text{ pF}$, See Figure 2	195.12	200		160			ns
$t_r(C)$ CLKOUT rise time		10			10			ns
$t_f(C)$ CLKOUT fall time		8			8			ns
$t_w(CL)$ Pulse duration, CLKOUT low		92			74			ns
$t_w(CH)$ Pulse duration, CLKOUT high		90			72			ns
$t_d(MCC)$ Delay time CLKIN \uparrow to CLKOUT \downarrow		25 [‡]			60 [‡]			25 [‡] 60 [‡] ns

[†] $t_c(C)$ is the cycle time of CLKOUT, i.e., $4 * t_c(MC)$ (4 times CLKIN cycle time if an external oscillator is used).

[‡]Values derived from characterization data and not tested.

timing requirements over recommended operating conditions

		TMS32010			TMS32010-25			UNIT
		MIN	NOM	MAX	MIN	NOM	MAX	
$t_c(MC)$ Master clock cycle time		48.78	50	150	40		150	ns
$t_r(MC)$ Rise time master clock input		5 [†]			5 [†]			10 [†] ns
$t_f(MC)$ Fall time master clock input		5 [†]			5 [†]			10 [†] ns
$t_w(MCP)$ Pulse duration master clock		0.475 $t_c(MC)$ [†]		0.525 $t_c(MC)$ [†]	0.475 $t_c(MC)$ [†]		0.525 $t_c(MC)$ [†]	ns
$t_w(MCL)$ Pulse duration master clock low, $t_c(MC) = 50 \text{ ns}$		20 [†]			18 [†]			ns
$t_w(MCH)$ Pulse duration master clock high, $t_c(MC) = 50 \text{ ns}$		20 [†]			18 [†]			ns

[†]Values derived from characterization data and not tested.



MEMORY AND PERIPHERAL INTERFACE TIMING

switching characteristics over recommended operating conditions

PARAMETER	TEST CONDITIONS	TMS32010			TMS32010-25			UNIT
		MIN	TYP	MAX	MIN	TYP	MAX	
t _{d1}	Delay time CLKOUT↓ to address bus valid	10 [†]		50	10 [†]		40	ns
t _{d2}	Delay time CLKOUT↓ to \overline{MEN} ↓	$\frac{1}{4}t_{c(C)} - 5^{\dagger}$		$\frac{1}{4}t_{c(C)} + 15$	$\frac{1}{4}t_{c(C)} - 5^{\dagger}$		$\frac{1}{4}t_{c(C)} + 12$	ns
t _{d3}	Delay time CLKOUT↓ to \overline{MEN} ↑	-10 [†]		15	-10 [†]		12	ns
t _{d4}	Delay time CLKOUT↓ to \overline{DEN} ↓	$\frac{1}{4}t_{c(C)} - 5^{\dagger}$		$\frac{1}{4}t_{c(C)} + 15$	$\frac{1}{4}t_{c(C)} - 5^{\dagger}$		$\frac{1}{4}t_{c(C)} + 12$	ns
t _{d5}	Delay time CLKOUT↓ to \overline{DEN} ↑	-10 [†]		15	-10 [†]		12	ns
t _{d6}	Delay time CLKOUT↓ to \overline{WE} ↓	$\frac{1}{2}t_{c(C)} - 5^{\dagger}$		$\frac{1}{2}t_{c(C)} + 15$	$\frac{1}{2}t_{c(C)} - 5^{\dagger}$		$\frac{1}{2}t_{c(C)} + 12$	ns
t _{d7}	Delay time CLKOUT↓ to \overline{WE} ↑	-10 [†]		15	-10 [†]		12	ns
t _{d8}	Delay time CLKOUT↓ to data bus OUT valid			$\frac{1}{4}t_{c(C)} + 65$			$\frac{1}{4}t_{c(C)} + 52$	ns
t _{d9}	Time after CLKOUT↓ that data bus starts to be driven	$\frac{1}{4}t_{c(C)} - 5^{\dagger}$			$\frac{1}{4}t_{c(C)} - 5^{\dagger}$			ns
t _{d10}	Time after CLKOUT↓ that data bus stops being driven			$\frac{1}{4}t_{c(C)} + 30^{\dagger}$			$\frac{1}{4}t_{c(C)} + 30^{\dagger}$	ns
t _v	Data bus OUT valid after CLKOUT↓	$\frac{1}{4}t_{c(C)} - 10$			$\frac{1}{4}t_{c(C)} - 10$			ns
t _{h(A-WMD)}	Address hold time after \overline{WE} ↑, \overline{MEN} ↑ or \overline{DEN} ↑ (see Note 1)	0			0			ns
t _{su(A-MD)}	Address bus setup time prior to \overline{MEN} ↓ or \overline{DEN} ↓	$\frac{1}{4}t_{c(C)} - 45$			$\frac{1}{4}t_{c(C)} - 35$			ns

[†]Values derived from characterization data and not tested.
NOTE 1: Address bus will be valid upon \overline{WE} ↑, \overline{DEN} ↑, or \overline{MEN} ↑.

timing requirements over recommended operating conditions

	TEST CONDITIONS	TMS32010			TMS32010-25			UNIT
		MIN	NOM	MAX	MIN	NOM	MAX	
t _{su(D)}	Setup time data bus valid prior to CLKOUT↓			50			40	ns
t _{h(D)}	Hold time data bus held valid after CLKOUT↓ (see Note 2)			0			0	ns

NOTE 2: Data may be removed from the data bus upon \overline{MEN} ↑ or \overline{DEN} ↑ preceding CLKOUT↓.

RESET (\overline{RS}) TIMING

switching characteristics over recommended operating conditions

PARAMETER	TEST CONDITIONS	MIN	TYP	MAX	UNIT
t_{d11} Delay time $\overline{DEN}\uparrow$, $\overline{WE}\uparrow$, and $\overline{MEN}\uparrow$ from \overline{RS}	$R_L = 825 \Omega$, $C_L = 100 \text{ pF}$, See Figure 2			$\frac{1}{2}t_{c(C)} + 50^\dagger$	ns
$t_{dis(R)}$ Data bus disable time after \overline{RS}				$\frac{1}{4}t_{c(C)} + 50^\dagger$	ns

[†]Values derived from characterization data and not tested.

timing requirements over recommended operating conditions

	TMS32010			TMS32010-25			UNIT
	MIN	NOM	MAX	MIN	NOM	MAX	
$t_{su(R)}$ Reset \overline{RS} setup time prior to CLKOUT (see Note 3)	50			40			ns
$t_w(R)$ \overline{RS} pulse duration	$5t_{c(C)}$			$5t_{c(C)}$			ns

NOTE 3: \overline{RS} can occur anytime during a clock cycle. Time given is minimum to ensure synchronous operation.

INTERRUPT (\overline{INT}) TIMING

timing requirements over recommended operating conditions

	TMS32010			TMS32010-25			UNIT
	MIN	NOM	MAX	MIN	NOM	MAX	
$t_f(INT)$ Fall time (\overline{INT})			15			15	ns
$t_w(INT)$ Pulse duration \overline{INT}	$t_{c(C)}$			$t_{c(C)}$			ns
$t_{su}(INT)$ Setup time $\overline{INT}\downarrow$ before $\overline{CLKOUT}\downarrow$	50			40			ns

I/O (\overline{BIO}) TIMING

timing requirements over recommended operating conditions

	TMS32010			TMS32010-25			UNIT
	MIN	NOM	MAX	MIN	NOM	MAX	
$t_f(IO)$ Fall time \overline{BIO}			15			15	ns
$t_w(IO)$ Pulse duration \overline{BIO}	$t_{c(C)}$			$t_{c(C)}$			ns
$t_{su}(IO)$ Setup time $\overline{BIO}\downarrow$ before $\overline{CLKOUT}\downarrow$	50			40			ns

CLOCK CHARACTERISTICS AND TIMING

The TMS32010-14 can use either its internal oscillator or an external frequency source for a clock.

internal clock option

The internal oscillator is enabled by connecting a crystal across X1 and X2/CLKIN (see Figure 1). The frequency of CLKOUT is one-fourth the crystal fundamental frequency. The crystal should be fundamental mode, and parallel resonant, with an effective series resistance of 30 ohms, a power dissipation of 1 mW, and be specified at a load capacitance of 20 pF.

PARAMETER	TEST CONDITIONS	MIN	NOM	MAX	UNIT
Crystal frequency f_x	0°C to 70°C	6.7		14.4	MHz
C1, C2	0°C to 70°C		10		pF

external clock option

An external frequency source can be used by injecting the frequency directly into X2/CLKIN with X1 left unconnected. The external frequency injected must conform to the specifications listed in the table below.

switching characteristics over recommended operating conditions

PARAMETER	TEST CONDITIONS	MIN	NOM	MAX	UNIT
$t_{c(C)}$ CLKOUT cycle time [†]	$R_L = 825 \Omega,$ $C_L = 100 \text{ pF},$ See Figure 2	277.78			ns
$t_r(C)$ CLKOUT rise time			10		ns
$t_f(C)$ CLKOUT fall time				8	ns
$t_w(CL)$ Pulse duration, CLKOUT low				131	ns
$t_w(CH)$ Pulse duration, CLKOUT high				129	ns
$t_d(MCC)$ Delay time CLKIN [†] to CLKOUT [↓]			25 [‡]		60 [‡]

[†] $t_{c(C)}$ is the cycle time of CLKOUT, i.e., $4 * t_{c(MC)}$ (4 times CLKIN cycle time if an external oscillator is used).

[‡]Values derived from characterization data and not tested.

timing requirements over recommended operating conditions

	MIN	NOM	MAX	UNIT
$t_c(MC)$ Master clock cycle time	69.5		150	ns
$t_r(MC)$ Rise time master clock input		5 [†]	10 [†]	ns
$t_f(MC)$ Fall time master clock input		5 [†]	10 [†]	ns
$t_w(MCP)$ Pulse duration master clock	0.475 $t_c(MC)$ [†]		0.525 $t_c(MC)$ [†]	ns
$t_w(MCL)$ Pulse duration master clock low, $t_c(MC) = 50 \text{ ns}$		20 [†]		ns
$t_w(MCH)$ Pulse duration master clock high, $t_c(MC) = 50 \text{ ns}$		20 [†]		ns

[†]Values derived from characterization data and not tested.

MEMORY AND PERIPHERAL INTERFACE TIMING

switching characteristics over recommended operating conditions

PARAMETER	TEST CONDITIONS	MIN	TYP	MAX	UNIT
t_{d1}	Delay time CLKOUT↓ to address bus valid (see Note 1)	10 [†]		50	ns
t_{d2}	Delay time CLKOUT↓ to \overline{MEN} ↓	$\frac{1}{4}t_{c(C)} - 5^{\dagger}$		$\frac{1}{4}t_{c(C)} + 15$	ns
t_{d3}	Delay time CLKOUT↓ to \overline{MEN} ↑	-10 [†]		15	ns
t_{d4}	Delay time CLKOUT↓ to \overline{DEN} ↓	$\frac{1}{4}t_{c(C)} - 5^{\dagger}$		$\frac{1}{4}t_{c(C)} + 15$	ns
t_{d5}	Delay time CLKOUT↓ to \overline{DEN} ↑	-10 [†]		15	ns
t_{d6}	Delay time CLKOUT↓ to \overline{WE} ↓	$\frac{1}{2}t_{c(C)} - 5^{\dagger}$		$\frac{1}{2}t_{c(C)} + 15$	ns
t_{d7}	Delay time CLKOUT↓ to \overline{WE} ↑	-10 [†]		15	ns
t_{d8}	Delay time CLKOUT↓ to data bus OUT valid			$\frac{1}{4}t_{c(C)} + 65$	ns
t_{d9}	Time after CLKOUT↓ that data bus starts to be driven	$\frac{1}{4}t_{c(C)} - 5^{\dagger}$			ns
t_{d10}	Time after CLKOUT↓ that data bus stops being driven			$\frac{1}{4}t_{c(C)} + 30^{\dagger}$	ns
t_v	Data bus OUT valid after CLKOUT↓	$\frac{1}{4}t_{c(C)} - 10$			ns
$t_{h(A-WMD)}$	Address hold time after \overline{WE} ↑, \overline{MEN} ↑, or \overline{DEN} ↑ (see Note 1)	0			ns
$t_{su(A-MD)}$	Address bus setup time prior to \overline{MEN} ↓ or \overline{DEN} ↓	$\frac{1}{4}t_{c(C)} - 45$			ns

[†]Values derived from characterization data and not tested.

NOTE 1: Address bus will be valid upon \overline{WE} ↑, \overline{DEN} ↑, or \overline{MEN} ↑.

timing requirements over recommended operating conditions

	TEST CONDITIONS	MIN	TYP	MAX	UNIT
$t_{su(D)}$	Setup time data bus valid prior to CLKOUT↓	50			ns
$t_{h(D)}$	Hold time data bus held valid after CLKOUT↓ (see Note 2)	0			ns

NOTE 2: Data may be removed from the data bus upon \overline{MEN} ↑ or \overline{DEN} ↑ preceding CLKOUT↓.

RESET (\overline{RS}) TIMING

switching characteristics over recommended operating conditions

PARAMETER	TEST CONDITIONS	MIN	TYP	MAX	UNIT
t_{d11} Delay time $\overline{DEN}\uparrow$, $\overline{WE}\uparrow$, and $\overline{MEN}\uparrow$ from \overline{RS}	$R_L = 825 \Omega$, $C_L = 100 \text{ pF}$, See Figure 2			$\frac{1}{2}t_{c(C)} + 50^\dagger$	ns
$t_{dis(R)}$ Data bus disable time after \overline{RS}				$\frac{1}{4}t_{c(C)} + 50^\dagger$	ns

[†]Values derived from characterization data and not tested.

timing requirements over recommended operating conditions

	MIN	NOM	MAX	UNIT
$t_{su(R)}$ Reset (\overline{RS}) setup time prior to CLKOUT (see Note 3)	50			ns
$t_w(R)$ \overline{RS} pulse duration	$5t_{c(C)}$			ns

NOTE 3: \overline{RS} can occur anytime during a clock cycle. Time given is minimum to ensure synchronous operation.

INTERRUPT (\overline{INT}) TIMING

timing requirements over recommended operating conditions

	MIN	TYP	MAX	UNIT
$t_f(INT)$ Fall time \overline{INT}			15	ns
$t_w(INT)$ Pulse duration \overline{INT}	$t_{c(C)}$			ns
$t_{su(INT)}$ Setup time $\overline{INT}\downarrow$ before CLKOUT \downarrow	50			ns

I/O (\overline{BIO}) TIMING

timing requirements over recommended operating conditions

	MIN	TYP	MAX	UNIT
$t_f(IO)$ Fall time \overline{BIO}			15	ns
$t_w(IO)$ Pulse duration \overline{BIO}	$t_{c(C)}$			ns
$t_{su(IO)}$ Setup time $\overline{BIO}\downarrow$ before CLKOUT \downarrow	50			ns

CLOCK CHARACTERISTICS AND TIMING

The TMS32011 can use either its internal oscillator or an external frequency source for a clock.

internal clock option

The internal oscillator is enabled by connecting a crystal across X1 and X2/CLKIN (see Figure 1). The frequency of CLKOUT is one-fourth the crystal fundamental frequency. The crystal should be fundamental mode, and parallel resonant, with an effective series resistance of 30 ohms, a power dissipation of 1 mW, and be specified at a load capacitance of 20 pF.

PARAMETER	TEST CONDITIONS	MIN	NOM	MAX	UNIT
Crystal frequency f_x	0°C to 70°C	6.7		20.5	MHz
C1, C2	0°C to 70°C		10		pF

external clock option

An external frequency source can be used by injecting the frequency directly into X2/CLKIN with X1 left unconnected. The external frequency injected must conform to the specifications listed in the table below.

switching characteristics over recommended operating conditions

PARAMETER	TEST CONDITIONS	MIN	NOM	MAX	UNIT
$t_c(C)$ CLKOUT cycle time [†]	$R_L = 825 \Omega$, $C_L = 100 \text{ pF}$, See Figure 2	195	12		ns
$t_r(C)$ CLKOUT rise time			10		ns
$t_f(C)$ CLKOUT fall time			8		ns
$t_w(CL)$ Pulse duration, CLKOUT low			92		ns
$t_w(CH)$ Pulse duration, CLKOUT high			90		ns
$t_d(MCC)$ Delay time CLKIN \uparrow to CLKOUT \downarrow			25 [‡]		60 [‡]

[†] $t_c(C)$ is the cycle time of CLKOUT, i.e., $4 * t_c(MC)$ (4 times CLKIN cycle time if an external oscillator is used).

[‡]Values derived from characterization data and not tested.

timing requirements over recommended operating conditions

	MIN	NOM	MAX	UNIT
$t_c(MC)$ Master clock cycle time	48.78		150 [†]	ns
$t_r(MC)$ Rise time master clock input		5 [†]	10 [†]	ns
$t_f(MC)$ Fall time master clock input		5 [†]	10 [†]	ns
$t_w(MCP)$ Pulse duration master clock		$0.475t_c(MC)$ [†]	$0.525t_c(MC)$ [†]	ns
$t_w(MCL)$ Pulse duration master clock low, $t_c(MC) = 50 \text{ ns}$		20 [†]		ns
$t_w(MCH)$ Pulse duration master clock high, $t_c(MC) = 50 \text{ ns}$		20 [†]		ns

[†]Values derived from characterization data and not tested.

MEMORY AND PERIPHERAL INTERFACE TIMING

switching characteristics over recommended operating conditions

PARAMETER		TEST CONDITIONS	MIN	TYP	MAX	UNIT
t_{d1}	Delay time CLKOUT↓ to address bus valid (see Note 1)	$R_L = 825 \Omega$, $C_L = 100 \text{ pF}$, See Figure 2	10†		50	ns
t_{d4}	Delay time CLKOUT↓ to $\overline{\text{DEN}}\downarrow$		$\frac{1}{2}t_{c(C)} - 5^\dagger$		$\frac{1}{2}t_{c(C)} + 15$	ns
t_{d5}	Delay time CLKOUT↓ to $\overline{\text{DEN}}\uparrow$		-10†		15	ns
t_{d6}	Delay time CLKOUT↓ to $\overline{\text{WE}}\downarrow$		$\frac{1}{2}t_{c(C)} - 5^\dagger$		$\frac{1}{2}t_{c(C)} + 15$	ns
t_{d7}	Delay time CLKOUT↓ to $\overline{\text{WE}}\uparrow$		-10†		15	ns
t_{d8}	Delay time CLKOUT↓ to data bus OUT valid				$\frac{1}{2}t_{c(C)} + 65$	ns
t_{d9}	Time after CLKOUT↓ that data bus starts to be driven			$\frac{1}{2}t_{c(C)} - 5^\dagger$		ns
t_{d10}	Time after CLKOUT↓ that data bus stops being driven				$\frac{1}{2}t_{c(C)} + 30^\dagger$	ns
t_v	Data bus OUT valid after CLKOUT↓			$\frac{1}{2}t_{c(C)} - 10$		ns
$t_{h(A-WMD)}$	Address hold time after $\overline{\text{WE}}\uparrow$ or $\overline{\text{DEN}}\uparrow$ (see Note 1)			0		ns
$t_{su(A-MD)}$	Address bus setup time prior to $\overline{\text{MEN}}\downarrow$ or $\overline{\text{DEN}}\downarrow$		$\frac{1}{2}t_{c(C)} - 45$		ns	

NOTE 1: Address bus will be held valid upon $\overline{\text{WE}}\uparrow$ or $\overline{\text{DEN}}\uparrow$.

†Values derived from characterization data and not tested.

timing requirements over recommended operating conditions

		TEST CONDITIONS	MIN	TYP	MAX	UNIT
$t_{su(D)}$	Setup time data bus valid prior to CLKOUT↓	$R_L = 825 \Omega$, $C_L = 100 \text{ pF}$, See Figure 2	50			ns
$t_{h(D)}$	Hold time data bus held valid after CLKOUT↓ (see Note 2)		0			ns

NOTE 2: Data may be removed from the data bus upon $\overline{\text{MEN}}\uparrow$ or $\overline{\text{DEN}}\uparrow$ preceding CLKOUT↓.

RESET $\overline{\text{RS}}$ TIMING

switching characteristics over recommended operating conditions

PARAMETER		TEST CONDITIONS	MIN	TYP	MAX	UNIT
t_{d11}	Delay time $\overline{\text{DEN}}\uparrow$, $\overline{\text{WE}}\uparrow$, and $\overline{\text{MEN}}\uparrow$ from $\overline{\text{RS}}$	$R_L = 825 \Omega$, $C_L = 100 \text{ pF}$, See Figure 2			$\frac{1}{2}t_{c(C)} + 50^\dagger$	ns
$t_{dis(R)}$	Data bus disable time after $\overline{\text{RS}}$				$\frac{1}{2}t_{c(C)} + 50^\dagger$	ns
t_{d12}	Delay time from $\overline{\text{RS}}\downarrow$ to high-impedance SCLK		100†		200†	ns
t_{d13}	Delay time from $\overline{\text{RS}}\downarrow$ to high-impedance DX1, DX0		100†		200†	ns

†Values derived from characterization data and not tested.

timing requirements over recommended operating conditions

	MIN	NOM	MAX	UNIT
$t_{su(R)}$ Reset (\overline{RS}) setup time prior to CLKOUT (see Note 3)	50			ns
$t_w(R)$ \overline{RS} pulse duration	$5t_c(C)$			ns

NOTE 3: \overline{RS} can occur anytime during a clock cycle. Time given is minimum to ensure synchronous operation.

INTERRUPT (\overline{INT}) TIMING**timing requirements over recommended operating conditions**

	MIN	NOM	MAX	UNIT
$t_f(INT)$ Fall time (\overline{INT})			15	ns
$t_w(INT)$ Pulse duration \overline{INT}	$t_c(C)$			ns
$t_{su}(INT)$ Setup time $\overline{INT}\downarrow$ before CLKOUT \downarrow	50			ns

I/O (\overline{BIO}) TIMING**timing requirements over recommended operating conditions**

	MIN	NOM	MAX	UNIT
$t_f(IO)$ Fall time (\overline{BIO})			15	ns
$t_w(IO)$ Pulse duration \overline{BIO}	$t_c(C)$			ns
$t_{su}(IO)$ Setup time $\overline{BIO}\downarrow$ before CLKOUT \downarrow	50			ns
$t_d(BIO)$ Delay time CLKOUT \downarrow to $\overline{BIO}\downarrow$ (in the peripheral mode)	$0.5t_c(C)^\dagger$		$0.5t_c(C) + 50$	ns

† Values derived from characterization data and not tested.

XF TIMING**switching characteristics over recommended operating conditions**

PARAMETER	TEST CONDITIONS	MIN	TYP	MAX	UNIT
$t_d(XF)$ Delay time CLKOUT \downarrow to valid XF	$R_L = 825 \Omega$, $C_L = 100 \text{ pF}$, See Figure 2	5^\dagger		115	ns

† Values derived from characterization and not tested.

SERIAL PORT TIMING

switching characteristics over recommended operating conditions

	MIN	TYP	MAX	UNIT
$t_d(\text{CH-FR})$ Internal framing (FR) delay from SCLK rising edge	20		115	ns
$t_d(\text{DX1-CL})$ DX bit 1 valid before SCLK falling edge	20			ns
$t_d(\text{DX2-CL})$ DX bit 2 valid before SCLK falling edge	20			ns

timing requirements over recommended operating conditions

	MIN	NOM	MAX	UNIT
$t_c(\text{SCLK})$ Serial port clock (SCLK) cycle time (see Note 4)	390		4770	ns
$t_f(\text{SCLK})$ Serial port clock (SCLK) fall time			50	ns
$t_r(\text{SCLK})$ Serial port clock (SCLK) rise time			50	ns
$t_w(\text{SCLKL})$ Serial port clock (SCLK) low-pulse duration (see Note 5)	185		2500	ns
$t_w(\text{SCLKH})$ Serial port clock (SCLK) high-pulse duration (see Note 5)	185		2500	
$t_{su}(\text{FS})$ $\overline{\text{FSX}}/\overline{\text{FSR}}$ setup time before SCLK falling edge	100			ns
$t_{su}(\text{DR})$ DR setup time before SCLK falling edge	20			ns
$t_h(\text{DR})$ DR hold time after SCLK falling edge	20			ns
$t_h(\text{DX})$ DX hold time after SCLK falling edge	$t_c(\text{SCLK})/2^\dagger$			ns

[†]This parameter is not tested.

NOTES: 4. Minimum cycle time is $2t_{c(C)}$ where $t_{c(C)}$ is CLKOUT cycle time.

5. The duty cycle of the serial port clock must be within 45 to 55 percent.

CMOS DEVICE ELECTRICAL SPECIFICATIONS

This section contains all the electrical specifications for the TMS320 CMOS first-generation devices. Refer to the top corner for the specific device.

absolute maximum ratings over specified temperature range (unless otherwise noted)[†]

Supply voltage range, V_{CC} [‡]	-0.3 V to 7 V
Input voltage range	-0.3 V to 15 V
Output voltage range	-0.3 V to 15 V
Continuous power dissipation: 20-MHz version	0.3 W
25-MHz version	0.35 W
Air temperature range above operating device: L version	<u>0°C to 70°C</u>
A version	-40°C to 85°C
Storage temperature range	-55°C to +150°C

[†]Stresses beyond those listed under "Absolute Maximum Ratings" may cause permanent damage to the device. This is a stress rating only and functional operation of the device at these or any other conditions beyond those indicated in the "Recommended Operating Conditions" section of this specification is not implied. Exposure to absolute-maximum-rated conditions for extended periods may affect device reliability.

[‡]All voltage values are with respect to V_{SS} .

recommended operating conditions

		MIN	NOM	MAX	UNIT
V_{CC} Supply voltage	EPROM devices	4.75	5	5.25	V
	All other devices	4.5	5	5.5	
V_{SS} Supply voltage			0		V
V_{IH} High-level input voltage	All inputs except CLKIN	2			V
	CLKIN	3			
V_{IL} Low-level input voltage	All inputs except MC/\overline{MP}			0.8	V
	MC/\overline{MP}			0.6	
I_{OH} High-level output current (all outputs)				-300	μA
I_{OL} Low-level output current (all outputs)				2	mA
T_A Operating free-air temperature	L version	0		70	°C
	A version	-40		85	

electrical characteristics over specified temperature range (unless otherwise noted)

PARAMETER		TEST CONDITIONS		MIN	TYP [†]	MAX	UNIT
V_{OH} High-level output voltage		$I_{OH} = \text{MAX}$		2.4	3		V
		$I_{OH} = 20 \mu A$ (see Note 6)		$V_{CC} - 0.4$ [‡]			V
V_{OL} Low-level output voltage		$I_{OL} = \text{MAX}$			0.3	0.5	V
I_{OZ} Off-state output current		$V_{CC} = \text{MAX}$	$V_O = 2.4 \text{ V}$			20	μA
			$V_O = 0.4 \text{ V}$			-20	
I_I Input current		$V_I = V_{SS} \text{ to } V_{CC}$	All inputs except CLKIN			± 20	μA
			CLKIN			± 50	
C_i Input capacitance	Data bus	$f = 1 \text{ MHz, All other pins } 0 \text{ V}$			25 [‡]		pF
	All others				15 [‡]		
C_o Output capacitance	Data bus				25 [‡]		pF
	All others				10 [‡]		

[†]All typical values are at $V_{CC} = 5 \text{ V, } T_A = 25^\circ\text{C}$.

[‡]Values derived from characterization data and not tested.

NOTE 6: This voltage specification is included for interface to HC logic. However, note that all of the other timing parameters defined in this data sheet are specified for TTL logic levels and will differ for HC logic levels.



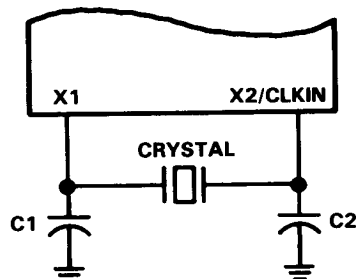

FIGURE 4. INTERNAL CLOCK OPTION

PARAMETER MEASUREMENT INFORMATION

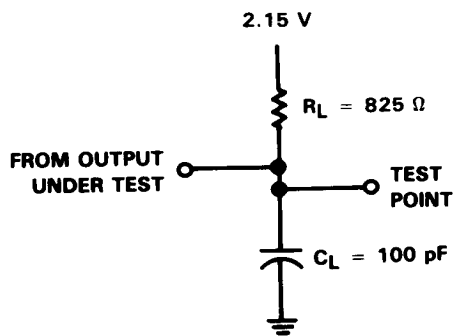

FIGURE 5. TEST LOAD CIRCUIT

electrical characteristics over specified temperature range (unless otherwise noted)

PARAMETER		TEST CONDITIONS	MIN	TYP†	MAX	UNIT
I _{CC} ‡	Supply current	TMS320C10		33	55	mA
		TMS320C10-25		40	65	mA

†All typical values are at V_{CC} = 5 V, T_A = 25°C.

‡I_{CC} characteristics are inversely proportional to temperature. For I_{CC} dependence on temperature, frequency, and loading, see Figure 9.

CLOCK CHARACTERISTICS AND TIMING

The TMS320C10 can use either its internal oscillator or an external frequency source for a clock.

internal clock option

The internal oscillator is enabled by connecting a crystal across X1 and X2/CLKIN (see Figure 4). The frequency of CLKOUT is one-fourth the crystal fundamental frequency. The crystal should be fundamental mode, and parallel resonant, with an effective series resistance of 30 ohms, a power dissipation of 1 mW, and be specified at a load capacitance of 20 pF.

PARAMETER		TEST CONDITIONS	MIN	NOM	MAX	UNIT
Crystal frequency f _x	TMS320C10	T _A = -40°C to 85°C	6.7		20.5	MHz
	TMS320C10-25	T _A = -40°C to 85°C	6.7		25.6	MHz
C1, C2		T _A = -40°C to 85°C		10		pF

external clock option

An external frequency source can be used by injecting the frequency directly into X2/CLKIN with X1 left unconnected. The external frequency injected must conform to the specifications listed in the table below.

switching characteristics over recommended operating conditions

PARAMETER	TEST CONDITIONS	TMS320C10			TMS320C10-25			UNIT	
		MIN	NOM	MAX	MIN	NOM	MAX		
t _c (C) CLKOUT cycle time†	R _L = 825 Ω, C _L = 100 pF, See Figure 5	195	120	200	156	25	160	ns	
t _r (C) CLKOUT rise time				10‡		10‡		ns	
t _f (C) CLKOUT fall time				8‡		8‡		ns	
t _w (CL) Pulse duration, CLKOUT low				92‡		72‡		ns	
t _w (CH) Pulse duration, CLKOUT high				90‡		70‡		ns	
t _d (MCC) Delay time CLKIN↑ to CLKOUT↓			25‡		60‡	25‡		50‡	ns

†t_c(C) is the cycle time of CLKOUT, i.e., 4*t_c(MC) (4 times CLKIN cycle time if an external oscillator is used).

‡Values derived from characterization data and not tested.

timing requirements over recommended operating conditions

		TMS320C10			TMS320C10-25			UNIT
		MIN	NOM	MAX	MIN	NOM	MAX	
t _c (MC) Master clock cycle time		48.78	50	150	39.06	40	150	ns
t _r (MC) Rise time master clock input			5†	10†		5†	10†	ns
t _f (MC) Fall time master clock input			5†	10†		5†	10†	ns
t _w (MCP) Pulse duration master clock		0.4t _c (MC)†		0.6t _c (MC)†	0.45t _c (MC)†		0.55t _c (MC)†	ns
t _w (MCL) Pulse duration master clock low			20†			15†		ns
t _w (MCH) Pulse duration master clock high			20†			15†		ns

†Values derived from characterization data and not tested.



MEMORY AND PERIPHERAL INTERFACE TIMING

switching characteristics over recommended operating conditions

PARAMETER	TEST CONDITIONS	TMS320C10			TMS320C10-25			UNIT
		MIN	TYP	MAX	MIN	TYP	MAX	
t _{d1}	Delay time CLKOUT↓ to address bus valid	10†			50			ns
t _{d2}	Delay time CLKOUT↓ to \overline{MEN} ↓	$\frac{1}{4}t_c(C) - 5^\dagger$			$\frac{1}{4}t_c(C) + 15$			ns
t _{d3}	Delay time CLKOUT↓ to \overline{MEN} ↑	-10†			15			ns
t _{d4}	Delay time CLKOUT↓ to \overline{DEN} ↓	$\frac{1}{4}t_c(C) - 5^\dagger$			$\frac{1}{4}t_c(C) + 15$			ns
t _{d5}	Delay time CLKOUT↓ to \overline{DEN} ↑	-10†			15			ns
t _{d6}	Delay time CLKOUT↓ to \overline{WE} ↓	$\frac{1}{2}t_c(C) - 5^\dagger$			$\frac{1}{2}t_c(C) + 15$			ns
t _{d7}	Delay time CLKOUT↓ to \overline{WE} ↑	-10†			15			ns
t _{d8}	Delay time CLKOUT↓ to data bus OUT valid				$\frac{1}{4}t_c(C) + 65$			ns
t _{d9}	Time after CLKOUT↓ that data bus starts to be driven	$\frac{1}{4}t_c(C) - 5^\dagger$			$\frac{1}{4}t_c(C) - 5^\dagger$			ns
t _{d10}	Time after CLKOUT↓ that data bus stops being driven				$\frac{1}{4}t_c(C) + 30^\dagger$			ns
t _v	Data bus OUT valid after CLKOUT↓	$\frac{1}{4}t_c(C) - 10$			$\frac{1}{4}t_c(C) - 10$			ns
t _{h(A-WMD)}	Address hold time after \overline{WE} ↑, \overline{MEN} ↑, or \overline{DEN} ↑ (see Note 7)	-10			-10			ns
t _{su(A-MD)}	Address bus setup time prior to \overline{MEN} ↓ or \overline{DEN} ↓	$\frac{1}{4}t_c(C) - 45$			$\frac{1}{4}t_c(C) - 35$			ns

†Values derived from characterization data and not tested.
NOTE 7: For interfacing I/O devices, see Figure 6.

timing requirements over recommended operating conditions

	TEST CONDITIONS	TMS320C10			TMS320C10-25			UNIT
		MIN	NOM	MAX	MIN	NOM	MAX	
t _{su(D)}	Setup time data bus valid prior to CLKOUT↓	50			40			ns
t _{h(D)}	Hold time data bus held valid after CLKOUT↓ (see Note 2)	0			0			ns

NOTE 2: Data may be removed from the data bus upon \overline{MEN} ↑ or \overline{DEN} ↑ preceding CLKOUT↓.

SUGGESTED I/O DECODE CIRCUIT

The circuit shown in Figure 6 is a design example for interfacing I/O devices to the TMS320C10. This circuit decodes the address for output operations using the OUT instruction. The same circuit can be used to decode input and output operations if the inverter ('ALS04) is replaced with a NAND gate and both \overline{DEN} and \overline{WE} are connected. Inputs and outputs can be decoded at the same port provided the output of the decoder ('AS137) is gated with the appropriate signal (\overline{DEN} or \overline{WE}) to select read or write (using an 'ALS32). Access times can be increased when the circuit shown in Figure 6 is repeated to support IN instructions with \overline{DEN} connected rather than \overline{WE} .

The table write (TBLW) function requires a different circuit. A detailed discussion of an example circuit for this function is described on page 315 of the application report, "Interfacing External Memory to the TMS32010," published in the book, *Digital Signal Processing Applications with the TMS320 Family*. A schematic of this circuit as shown on page 318 of that book.

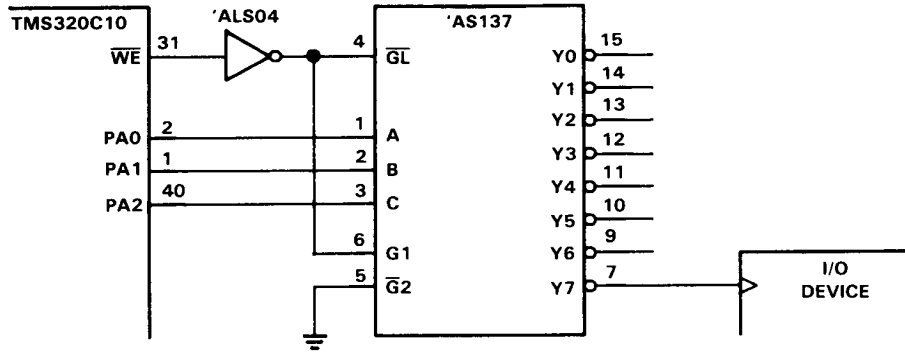

FIGURE 6. I/O DECODE CIRCUIT

RESET (\overline{RS}) TIMING

switching characteristics over recommended operating conditions

PARAMETER	TEST CONDITIONS	MIN	TYP	MAX	UNIT
t_{d11} Delay time $\overline{DEN}\uparrow$, $\overline{WE}\uparrow$, and $\overline{MEN}\uparrow$ from \overline{RS}	$R_L = 825 \Omega$, $C_L = 100 \text{ pF}$, See Figure 5		$\frac{1}{2} t_{c(C)} + 50^\dagger$		ns
$t_{dis(R)}$ Data bus disable time after \overline{RS}			$\frac{1}{4} t_{c(C)} + 50^\dagger$		ns

[†]These values were derived from characterization data and not tested.

timing requirements over recommended operating conditions

	TMS320C10			TMS320C10-25			UNIT
	MIN	NOM	MAX	MIN	NOM	MAX	
$t_{su(R)}$ Reset (\overline{RS}) setup time prior to CLKOUT (see Note 3)	50			40			ns
$t_w(R)$ \overline{RS} pulse duration	$5t_{c(C)}$			$5t_{c(C)}$			ns

NOTE 3: \overline{RS} can occur anytime during a clock cycle. Time given is minimum to ensure synchronous operation.

INTERRUPT (\overline{INT}) TIMING

timing requirements over recommended operating conditions

	TMS320C10			TMS320C10-25			UNIT
	MIN	NOM	MAX	MIN	NOM	MAX	
$t_f(INT)$ Fall time \overline{INT}	15			15			ns
$t_w(INT)$ Pulse duration \overline{INT}	$t_{c(C)}$			$t_{c(C)}$			ns
$t_{su(INT)}$ Setup time $\overline{INT}\downarrow$ before CLKOUT \downarrow	50			40			ns

I/O (\overline{BIO}) TIMING

timing requirements over recommended operating conditions

	TMS320C10			TMS320C10-25			UNIT
	MIN	NOM	MAX	MIN	NOM	MAX	
$t_f(IO)$ Fall time \overline{BIO}	15			15			ns
$t_w(IO)$ Pulse duration \overline{BIO}	$t_{c(C)}$			$t_{c(C)}$			ns
$t_{su(IO)}$ Setup time $\overline{BIO}\downarrow$ before CLKOUT \downarrow	50			40			ns

electrical characteristics over specified temperature range (unless otherwise noted)

PARAMETER		TEST CONDITIONS	MIN	TYP†	MAX	UNIT
I _{CC} †	Supply current	TMS320C15 f = 20.5 MHz, V _{CC} = 5.5 V		45		mA
		TMS320C15-25 f = 25.6 MHz, V _{CC} = 5.5 V		50		
		TMS320E15 f = 20.5 MHz, V _{CC} = 5.25 V		60		

†All typical values are at V_{CC} = 5 V, T_A = 25°C.

‡I_{CC} characteristics are inversely proportional to temperature. For I_{CC} dependence on temperature, frequency, and loading, see Figure 9.

CLOCK CHARACTERISTICS AND TIMING

The TMS320C15/E15 can use either its internal oscillator or an external frequency source for a clock.

internal clock option

The internal oscillator is enabled by connecting a crystal across X1 and X2/CLKIN (see Figure 4). The frequency of CLKOUT is one-fourth the crystal fundamental frequency. The crystal should be fundamental mode, and parallel resonant, with an effective series resistance of 30 ohms, a power dissipation of 1 mW, and be specified at a load capacitance of 20 pF.

PARAMETER		TEST CONDITIONS	MIN	NOM	MAX	UNIT
Crystal frequency f _x	TMS320C15/E15	T _A = 0°C to 70°C	6.7		20.5	MHz
	TMS320C15-25	T _A = 0°C to 70°C	6.7		25.6	MHz
C1, C2		T _A = 0°C to 70°C		10		pF

external clock option

An external frequency source can be used by injecting the frequency directly into X2/CLKIN with X1 left unconnected. The external frequency injected must conform to the specifications listed in the table below.

switching characteristics over recommended operating conditions

PARAMETER		TEST CONDITIONS	TMS320C15/E15			TMS320C15-25			UNIT
			MIN	NOM	MAX	MIN	NOM	MAX	
t _c (C)	CLKOUT cycle time†	R _L = 825 Ω, C _L = 100 pF, See Figure 5	195.2	200		156.25	160		ns
t _r (C)	CLKOUT rise time				10‡		10‡		ns
t _f (C)	CLKOUT fall time				8‡		8‡		ns
t _w (CL)	Pulse duration, CLKOUT low				92‡		72‡		ns
t _w (CH)	Pulse duration, CLKOUT high				90‡		70‡		ns
t _d (MCC)	Delay time CLKIN↑ to CLKOUT↓			25‡		60‡	25‡		50‡

†t_c(C) is the cycle time of CLKOUT, i.e., 4*t_c(MC) (4 times CLKIN cycle time if an external oscillator is used).

‡Values derived from characterization data and not tested.

ADVANCE INFORMATION

ADVANCE INFORMATION documents contain information on new products in the sampling or preproduction phase of development. Characteristic data and other specifications are subject to change without notice.



POST OFFICE BOX 1443 • HOUSTON, TEXAS 77001

timing requirements over recommended operating conditions

		TMS320C15/E15			TMS320C15-25			UNIT
		MIN	NOM	MAX	MIN	NOM	MAX	
$t_c(\text{MC})$	Master clock cycle time	48.78	50	150	39.06	40	150	ns
$t_r(\text{MC})$	Rise time master clock input		5 [†]	10 [†]		5 [†]	10 [†]	ns
$t_f(\text{MC})$	Fall time master clock input		5 [†]	10 [†]		5 [†]	10 [†]	ns
$t_w(\text{MCP})$	Pulse duration master clock	0.4 $t_c(\text{MC})$ [†]		0.6 $t_c(\text{MC})$ [†]	0.45 $t_c(\text{MC})$ [†]		0.55 $t_c(\text{MC})$ [†]	ns
$t_w(\text{MCL})$	Pulse duration master clock low		20 [†]			15 [†]		ns
$t_w(\text{MCH})$	Pulse duration master clock high		20 [†]			15 [†]		ns

[†]Values derived from characterization data and not tested.

MEMORY AND PERIPHERAL INTERFACE TIMING

switching characteristics over recommended operating conditions

PARAMETER	TEST CONDITIONS	TMS320C15/E15			TMS320C15-25			UNIT
		MIN	TYP	MAX	MIN	TYP	MAX	
t_{d1}	Delay time CLKOUT↓ to address bus valid		10 [†]	50		10 [†]	40	ns
t_{d2}	Delay time CLKOUT↓ to $\overline{\text{MEN}}\downarrow$		$\frac{1}{4}t_c(\text{C}) - 5$ [†]	$\frac{1}{4}t_c(\text{C}) + 15$		$\frac{1}{4}t_c(\text{C}) - 5$ [†]	$\frac{1}{4}t_c(\text{C}) + 12$	ns
t_{d3}	Delay time CLKOUT↓ to $\overline{\text{MEN}}\uparrow$		-10 [†]	15		-10 [†]	12	ns
t_{d4}	Delay time CLKOUT↓ to $\overline{\text{DEN}}\downarrow$		$\frac{1}{4}t_c(\text{C}) - 5$ [†]	$\frac{1}{4}t_c(\text{C}) + 15$		$\frac{1}{4}t_c(\text{C}) - 5$ [†]	$\frac{1}{4}t_c(\text{C}) + 12$	ns
t_{d5}	Delay time CLKOUT↓ to $\overline{\text{DEN}}\uparrow$		-10 [†]	15		-10 [†]	12	ns
t_{d6}	Delay time CLKOUT↓ to $\overline{\text{WE}}\downarrow$	$R_L = 825 \Omega,$ $C_L = 100 \text{ pF},$ See Figure 5	$\frac{1}{2}t_c(\text{C}) - 5$ [†]	$\frac{1}{2}t_c(\text{C}) + 15$	$\frac{1}{2}t_c(\text{C}) - 5$ [†]	$\frac{1}{2}t_c(\text{C}) + 12$		ns
t_{d7}	Delay time CLKOUT↓ to $\overline{\text{WE}}\uparrow$		-10 [†]	15	-10 [†]	12		ns
t_{d8}	Delay time CLKOUT↓ to data bus OUT valid			$\frac{1}{4}t_c(\text{C}) + 65$		$\frac{1}{4}t_c(\text{C}) + 52$		ns
t_{d9}	Time after CLKOUT↓ that data bus starts to be driven			$\frac{1}{4}t_c(\text{C}) - 5$ [†]		$\frac{1}{4}t_c(\text{C}) - 5$ [†]		ns
t_{d10}	Time after CLKOUT↓ that data bus stops being driven			$\frac{1}{4}t_c(\text{C}) + 30$ [†]		$\frac{1}{4}t_c(\text{C}) + 30$ [†]		ns
t_v	Data bus OUT valid after CLKOUT↓			$\frac{1}{4}t_c(\text{C}) - 10$		$\frac{1}{4}t_c(\text{C}) - 10$		ns
$t_{h(\text{A-WMD})}$	Address hold time after $\overline{\text{WE}}\uparrow, \overline{\text{MEN}}\uparrow,$ or $\overline{\text{DEN}}\uparrow$ (see Note 7)			-10		-10		ns
$t_{su(\text{A-MD})}$	Address bus setup time prior to $\overline{\text{MEN}}\downarrow$ or $\overline{\text{DEN}}\downarrow$			$\frac{1}{4}t_c(\text{C}) - 45$		$\frac{1}{4}t_c(\text{C}) - 35$		ns

[†]Values derived from characterization data and not tested.

NOTE 7: For interfacing I/O devices, see Figure 6.

timing requirements over recommended operating conditions

		TEST CONDITIONS	TMS320C15/E15			TMS320C15-25			UNIT
			MIN	NOM	MAX	MIN	NOM	MAX	
$t_{su(\text{D})}$	Setup time data bus valid prior to CLKOUT↓	$R_L = 825 \Omega,$	50			40			ns
$t_{h(\text{D})}$	Hold time data bus held valid after CLKOUT↓ (see Note 2)	$C_L = 100 \text{ pF},$ See Figure 5	0			0			ns

NOTE 2: Data may be removed from the data bus upon $\overline{\text{MEN}}\uparrow$ or $\overline{\text{DEN}}\uparrow$ preceding CLKOUT↓.

ADVANCE INFORMATION documents contain information on new products in the sampling or preproduction phase of development. Characteristic data and other specifications are subject to change without notice.



POST OFFICE BOX 1443 • HOUSTON, TEXAS 77001

ADVANCE INFORMATION

RESET (\overline{RS}) TIMING

switching characteristics over recommended operating conditions

PARAMETER	TEST CONDITIONS	MIN	TYP	MAX	UNIT
t_{d11} Delay time $\overline{DEN}\uparrow$, $\overline{WE}\uparrow$, and $\overline{MEN}\uparrow$ from \overline{RS}	$R_L = 825 \Omega$, $C_L = 100 \text{ pF}$, See Figure 5			$\frac{1}{2}t_{c(C)} + 50^\dagger$	ns
$t_{dis(R)}$ Data bus disable time after \overline{RS}				$\frac{1}{4}t_{c(C)} + 50^\dagger$	ns

† These values were derived from characterization data and not tested.

timing requirements over recommended operating conditions

	TMS320C15/E15			TMS320C15-25			UNIT
	MIN	NOM	MAX	MIN	NOM	MAX	
$t_{su(R)}$ Reset (\overline{RS}) setup time prior to CLKOUT (see Note 3)	50			40			ns
$t_w(R)$ \overline{RS} pulse duration	$5t_{c(C)}$			$5t_{c(C)}$			ns

NOTE 3: \overline{RS} can occur anytime during a clock cycle. Time given is minimum to ensure synchronous operation.

INTERRUPT (\overline{INT}) TIMING

timing requirements over recommended operating conditions

	TMS320C15/E15			TMS320C15-25			UNIT
	MIN	NOM	MAX	MIN	NOM	MAX	
$t_f(INT)$ Fall time \overline{INT}			15			15	ns
$t_w(INT)$ Pulse duration \overline{INT}	$t_{c(C)}$			$t_{c(C)}$			ns
$t_{su(INT)}$ Setup time $\overline{INT}\downarrow$ before CLKOUT \downarrow	50			40			ns

I/O (\overline{BIO}) TIMING

timing requirements over recommended operating conditions

	TMS320C15/E15			TMS320C15-25			UNIT
	MIN	NOM	MAX	MIN	NOM	MAX	
$t_f(IO)$ Fall time \overline{BIO}			15			15	ns
$t_w(IO)$ Pulse duration \overline{BIO}	$t_{c(C)}$			$t_{c(C)}$			ns
$t_{su(IO)}$ Setup time $\overline{BIO}\downarrow$ before CLKOUT \downarrow	50			40			ns

ADVANCE INFORMATION

ADVANCE INFORMATION documents contain information on new products in the sampling or preproduction phase of development. Characteristic data and other specifications are subject to change without notice.



POST OFFICE BOX 1443 • HOUSTON, TEXAS 77001

electrical characteristics over specified temperature range (unless otherwise noted)

PARAMETER		TEST CONDITIONS	MIN	TYP†	MAX	UNIT
I _{CC} ‡	Supply current	TMS320C17	f = 20.5 MHz, V _{CC} = 5.5 V		50	mA
		TMS320C17-25	f = 25.6 MHz, V _{CC} = 5.5 V		55	
		TMS320E17	f = 20.5 MHz, V _{CC} = 5.25 V		65	

†All typical values are at V_{CC} = 5 V, T_A = 25°C.

‡I_{CC} characteristics are inversely proportional to temperature. For I_{CC} dependence on temperature, frequency, and loading, see Figure 9.

CLOCK CHARACTERISTICS AND TIMING

The TMS320C17/E17 can use either its internal oscillator or an external frequency source for a clock.

internal clock option

The internal oscillator is enabled by connecting a crystal across X1 and X2/CLKIN (see Figure 4). The frequency of CLKOUT is one-fourth the crystal fundamental frequency. The crystal should be fundamental mode, and parallel resonant, with an effective series resistance of 30 ohms, a power dissipation of 1 mW, and be specified at a load capacitance of 20 pF.

PARAMETER		TEST CONDITIONS	MIN	NOM	MAX	UNIT
Crystal frequency f _x	TMS320C17/E17	T _A = 0°C to 70°C	6.7		20.5	MHz
	TMS320C17-25	T _A = 0°C to 70°C	6.7		25.6	MHz
C1, C2		T _A = 0°C to 70°C		10		pF

external clock option

An external frequency source can be used by injecting the frequency directly into X2/CLKIN with X1 left unconnected. The external frequency injected must conform to the specifications listed in the table below.

switching characteristics over recommended operating conditions

PARAMETER		TEST CONDITIONS	TMS320C17/E17			TMS320C17-25			UNIT	
			MIN	NOM	MAX	MIN	NOM	MAX		
t _c (C)	CLKOUT cycle time†	R _L = 825 Ω, C _L = 100 pF, See Figure 5	195.12	200		156.25	160		ns	
t _r (C)	CLKOUT rise time			10‡			10‡		ns	
t _f (C)	CLKOUT fall time				8‡		8‡		ns	
t _w (CL)	Pulse duration, CLKOUT low				92‡		72‡		ns	
t _w (CH)	Pulse duration, CLKOUT high				90‡		70‡		ns	
t _d (MCC)	Delay time CLKIN↑ to CLKOUT↓			25‡		60‡	25‡		50‡	ns

†t_c(C) is the cycle time of CLKOUT, i.e., 4*t_c(MC) (4 times CLKIN cycle time if an external oscillator is used).

‡Values derived from characterization data and not tested.

ADVANCE INFORMATION

ADVANCE INFORMATION documents contain information on new products in the sampling or preproduction phase of development. Characteristic data and other specifications are subject to change without notice.



POST OFFICE BOX 1443 • HOUSTON, TEXAS 77001

timing requirements over recommended operating conditions

		TMS320C17/E17			TMS320C17-25			UNIT
		MIN	NOM	MAX	MIN	NOM	MAX	
$t_c(\text{MC})$	Master clock cycle time	48.78	50	150	39.06	40	150	ns
$t_r(\text{MC})$	Rise time master clock input		5 [†]	10 [†]		5 [†]	10 [†]	ns
$t_f(\text{MC})$	Fall time master clock input		5 [†]	10 [†]		5 [†]	10 [†]	ns
$t_w(\text{MCP})$	Pulse duration master clock	0.4 $t_c(\text{MC})$ [†]		0.6 $t_c(\text{MC})$ [†]	0.45 $t_c(\text{MC})$ [†]		0.55 $t_c(\text{MC})$ [†]	ns
$t_w(\text{MCL})$	Pulse duration master clock low		20 [†]			15 [†]		ns
$t_w(\text{MCH})$	Pulse duration master clock high		20 [†]			15 [†]		ns

[†]Values derived from characterization data and not tested.

MEMORY AND PERIPHERAL INTERFACE TIMING

switching characteristics over recommended operating conditions

PARAMETER	TEST CONDITIONS	TMS320C17/E17			TMS320C17-25			UNIT
		MIN	TYP	MAX	MIN	TYP	MAX	
t_{d1}	Delay time CLKOUT \downarrow to address bus valid		10 [†]	50		10 [†]	40	ns
t_{d4}	Delay time CLKOUT \downarrow to $\overline{\text{DEN}}\downarrow$		$\frac{1}{4}t_c(\text{C}) - 5$ [†]	$\frac{1}{4}t_c(\text{C}) + 15$		$\frac{1}{4}t_c(\text{C}) - 5$ [†]	$\frac{1}{4}t_c(\text{C}) + 12$	ns
t_{d5}	Delay time CLKOUT \downarrow to $\overline{\text{DEN}}\uparrow$		-10 [†]	15		-10 [†]	12	ns
t_{d6}	Delay time CLKOUT \downarrow to $\overline{\text{WE}}\downarrow$		$\frac{1}{2}t_c(\text{C}) - 5$ [†]	$\frac{1}{2}t_c(\text{C}) + 15$		$\frac{1}{2}t_c(\text{C}) - 5$ [†]	$\frac{1}{2}t_c(\text{C}) + 12$	ns
t_{d7}	Delay time CLKOUT \downarrow to $\overline{\text{WE}}\uparrow$		-10 [†]	15		-10 [†]	12	ns
t_{d8}	Delay time CLKOUT \downarrow to data bus OUT valid			$\frac{1}{4}t_c(\text{C}) + 65$			$\frac{1}{4}t_c(\text{C}) + 52$	ns
t_{d9}	Time after CLKOUT \downarrow that data bus starts to be driven		$\frac{1}{4}t_c(\text{C}) - 5$ [†]			$\frac{1}{4}t_c(\text{C}) - 5$ [†]		ns
t_{d10}	Time after CLKOUT \downarrow that data bus stops being driven			$\frac{1}{4}t_c(\text{C}) + 30$ [†]			$\frac{1}{4}t_c(\text{C}) + 30$ [†]	ns
t_v	Data bus OUT valid after CLKOUT \downarrow		$\frac{1}{4}t_c(\text{C}) - 10$			$\frac{1}{4}t_c(\text{C}) - 10$		ns
$t_h(\text{A-WMD})$	Address hold time after $\overline{\text{WE}}\uparrow$ or $\overline{\text{DEN}}\uparrow$ (see Note 7)		-10			-10		ns
$t_{su}(\text{A-MD})$	Address bus setup time prior to $\overline{\text{DEN}}\downarrow$		$\frac{1}{4}t_c(\text{C}) - 45$			$\frac{1}{4}t_c(\text{C}) - 35$		ns

[†]Values derived from characterization data and not tested.

NOTE 7: For interfacing I/O devices, see Figure 6.

timing requirements over recommended operating conditions

	TEST CONDITIONS	TMS320C17/E17			TMS320C17-25			UNIT
		MIN	NOM	MAX	MIN	NOM	MAX	
$t_{su}(\text{D})$	Setup time data bus valid prior to CLKOUT \downarrow		50			40		ns
$t_h(\text{D})$	Hold time data bus held valid after CLKOUT \downarrow (see Note 2)		0			0		ns

NOTE 2: Data may be removed from the data bus upon $\overline{\text{DEN}}\uparrow$ preceding CLKOUT \downarrow .

ADVANCE INFORMATION

ADVANCE INFORMATION documents contain information on new products in the sampling or preproduction phase of development. Characteristic data and other specifications are subject to change without notice.



POST OFFICE BOX 1443 • HOUSTON, TEXAS 77001

RESET (\overline{RS}) TIMING

switching characteristics over recommended operating conditions

PARAMETER		TEST CONDITIONS	MIN	TYP	MAX	UNIT
t_{d11}	Delay time $\overline{DEN}\uparrow$, $\overline{WE}\uparrow$, and $\overline{MEN}\uparrow$ from \overline{RS}	$R_L = 825 \Omega$, $C_L = 100 \text{ pF}$, See Figure 5			$\frac{1}{2}t_{c(C)} + 50^\dagger$	ns
$t_{dis(R)}$	Data bus disable time after \overline{RS}				$\frac{1}{4}t_{c(C)} + 50^\dagger$	ns
t_{d12}	Delay time from $\overline{RS}\downarrow$ to high-impedance SCLK		100 †		200 †	ns
t_{d13}	Delay time from $\overline{RS}\downarrow$ to high-impedance DX1, DX0		100 †		200 †	ns

† Values derived from characterization data and not tested.

timing requirements over recommended operating conditions

	TMS320C17/E17			TMS320C17-25			UNIT
	MIN	NOM	MAX	MIN	NOM	MAX	
$t_{su(R)}$ Reset (\overline{RS}) setup time prior to CLKOUT (see Note 3)	50			40			ns
$t_{w(R)}$ \overline{RS} pulse duration	$5t_{c(C)}$			$5t_{c(C)}$			ns

NOTE 3: RS can occur anytime during a clock cycle. Time given is minimum to ensure synchronous operation.

INTERRUPT (\overline{EXINT}) TIMING

timing requirements over recommended operating conditions

	TMS320C17/E17			TMS320C17-25			UNIT
	MIN	NOM	MAX	MIN	NOM	MAX	
$t_{f(INT)}$ Fall time \overline{EXINT}			15			15	ns
$t_{w(INT)}$ Pulse duration \overline{EXINT}	$t_{c(C)}$			$t_{c(C)}$			ns
$t_{su(INT)}$ Setup time $\overline{EXINT}\downarrow$ before CLKOUT \downarrow	50			40			ns

I/O (\overline{BIO}) TIMING

timing requirements over recommended operating conditions

	TMS320C17/E17			TMS320C17-25			UNIT
	MIN	NOM	MAX	MIN	NOM	MAX	
$t_{f(IO)}$ Fall time \overline{BIO}			15			15	ns
$t_{w(IO)}$ Pulse duration \overline{BIO}	$t_{c(C)}$			$t_{c(C)}$			ns
$t_{su(IO)}$ Setup time $\overline{BIO}\downarrow$ before CLKOUT \downarrow	50			40			ns

switching characteristics over recommended operating conditions

PARAMETER	TEST CONDITIONS	MIN	TYP	MAX	UNIT
$t_{d(XF)}$ Delay time CLKOUT \downarrow to valid XF	$R_L = 825 \Omega$, $C_L = 100 \text{ pF}$, See Figure 5		5 †	115	ns

† Values derived from characterization data and not tested.

ADVANCE INFORMATION

ADVANCE INFORMATION documents contain information on new products in the sampling or preproduction phase of development. Characteristic data and other specifications are subject to change without notice.



POST OFFICE BOX 1443 • HOUSTON, TEXAS 77001

SERIAL PORT TIMING

switching characteristics over recommended operating conditions

PARAMETER		MIN	TYP	MAX	UNIT
$t_d(\text{CH-FR})$	Internal framing (FR) delay from SCLK rising edge			70	ns
$t_d(\text{DX1-CL})$	DX bit 1 valid before SCLK falling edge	20			ns
$t_d(\text{DX2-CL})$	DX bit 2 valid before SCLK falling edge	20			ns

timing requirements over recommended operating conditions

		MIN	NOM	MAX	UNIT
$t_c(\text{SCLK})$	Serial port clock (SCLK) cycle time (see Note 8)	390		4770	ns
$t_f(\text{SCLK})$	Serial port clock (SCLK) fall time			30	ns
$t_r(\text{SCLK})$	Serial port clock (SCLK) rise time			30	ns
$t_w(\text{SCLKL})$	Serial port clock (SCLK) low-pulse duration (see Note 9)	185		2500	ns
$t_w(\text{SCLKH})$	Serial port clock (SCLK) high-pulse duration (see Note 9)	185		2500	
$t_{su}(\text{FS})$	$\overline{\text{FSX}}/\overline{\text{FSR}}$ setup time before SCLK falling edge	100			ns
$t_{su}(\text{DR})$	DR setup time before SCLK falling edge	20			ns
$t_h(\text{DR})$	DR hold time after SCLK falling edge	20			ns
$t_h(\text{DX})$	DX hold time after SCLK falling edge	$t_c(\text{SCLK})/2$			ns

NOTES: 8. Minimum cycle time is $2t_{c(C)}$ where $t_{c(C)}$ is CLKOUT cycle time.
9. The duty cycle of the serial port clock must be within 45 to 55 percent.

COPROCESSOR INTERFACE TIMING

switching characteristics over recommended operating conditions

PARAMETER		MIN	NOM	MAX	UNIT
$t_d(\text{R-A})$	$\overline{\text{RD}}$ low to $\overline{\text{TBLF}}$ high			75	ns
$t_d(\text{W-A})$	$\overline{\text{WR}}$ low to $\overline{\text{RBLE}}$ high			75	ns
$t_a(\text{LPR})$	$\overline{\text{RD}}$ low to data valid			60	ns
$t_h(\text{LPR})$	Data hold time after $\overline{\text{RD}}$ high	50			ns

timing requirements over recommended operating conditions

		MIN	NOM	MAX	UNIT
$t_h(\text{BA})$	Byte address hold time after $\overline{\text{WR}}$ or $\overline{\text{RD}}$ high	25			ns
$t_{su}(\text{BA})$	Byte address setup time to $\overline{\text{WR}}$ or $\overline{\text{RD}}$ low	40			ns
$t_{su}(\text{LP})$	Data setup time to $\overline{\text{WR}}$ high	30			ns
$t_h(\text{LP})$	Data hold time after $\overline{\text{WR}}$ high	25			ns
$t_w(\text{LP})$	$\overline{\text{WR}}$ low-pulse duration	60			ns

ADVANCE INFORMATION

ADVANCE INFORMATION documents contain information on new products in the sampling or preproduction phase of development. Characteristic data and other specifications are subject to change without notice.



POST OFFICE BOX 1443 • HOUSTON, TEXAS 77001

TIMING DIAGRAMS

This section contains all the timing diagrams for the TMS320 first-generation devices. Refer to the top corner for the specific device.

Timing measurements are referenced to and from a low voltage of 0.8 volts and a high voltage of 2.0 volts, unless otherwise noted.

clock timing

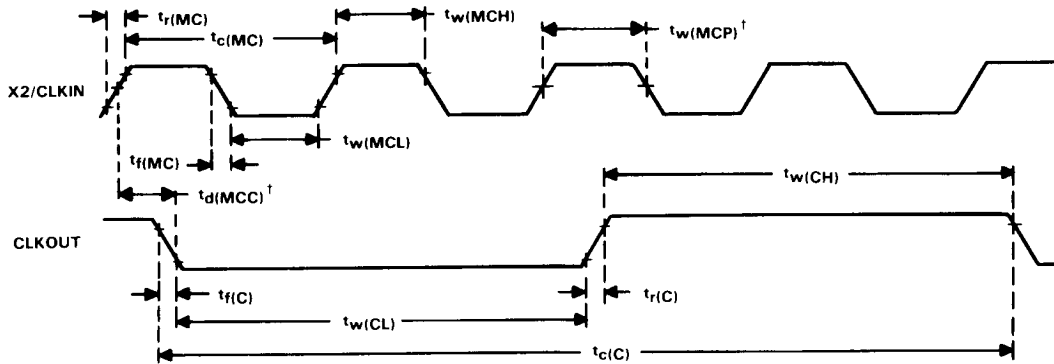

† $t_d(MCC)$ and $t_w(MCP)$ are referenced to an intermediate level of 1.5 volts on the CLKIN waveform.

memory read timing

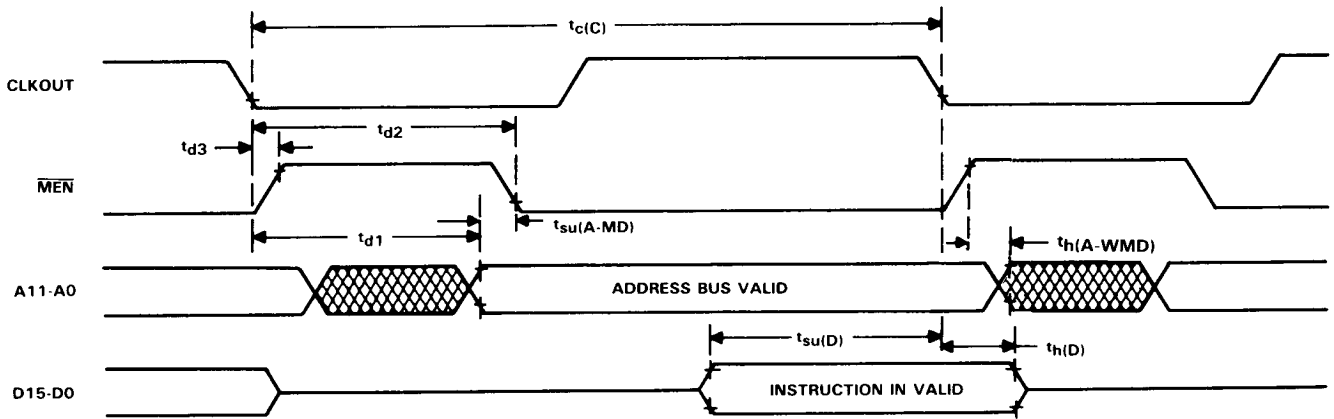

TMS320 FIRST-GENERATION DEVICES

TBLR instruction timing

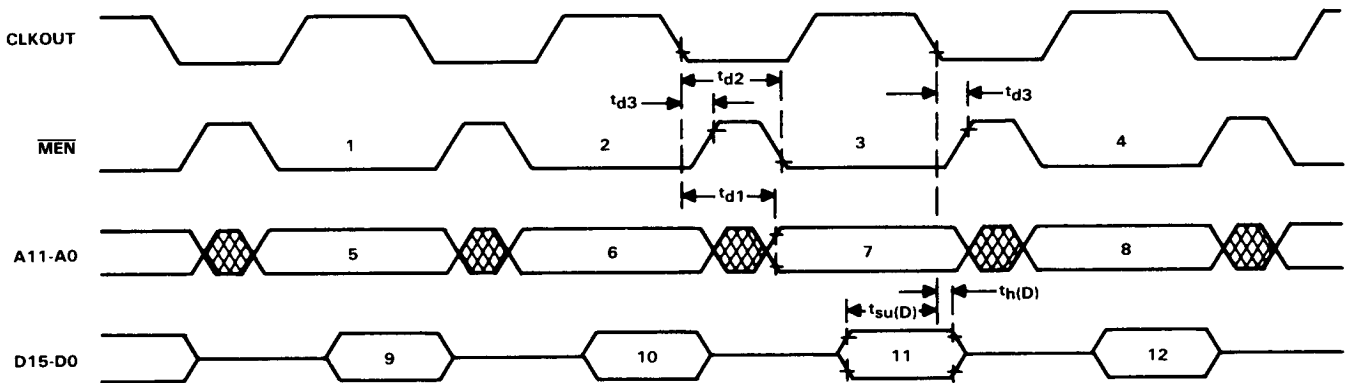

LEGEND:

- | | |
|------------------------------|--------------------------|
| 1. TBLR INSTRUCTION PREFETCH | 7. ADDRESS BUS VALID |
| 2. DUMMY PREFETCH | 8. ADDRESS BUS VALID |
| 3. DATA FETCH | 9. INSTRUCTION IN VALID |
| 4. NEXT INSTRUCTION PREFETCH | 10. INSTRUCTION IN VALID |
| 5. ADDRESS BUS VALID | 11. DATA IN VALID |
| 6. ADDRESS BUS VALID | 12. INSTRUCTION IN VALID |

TBLW instruction timing

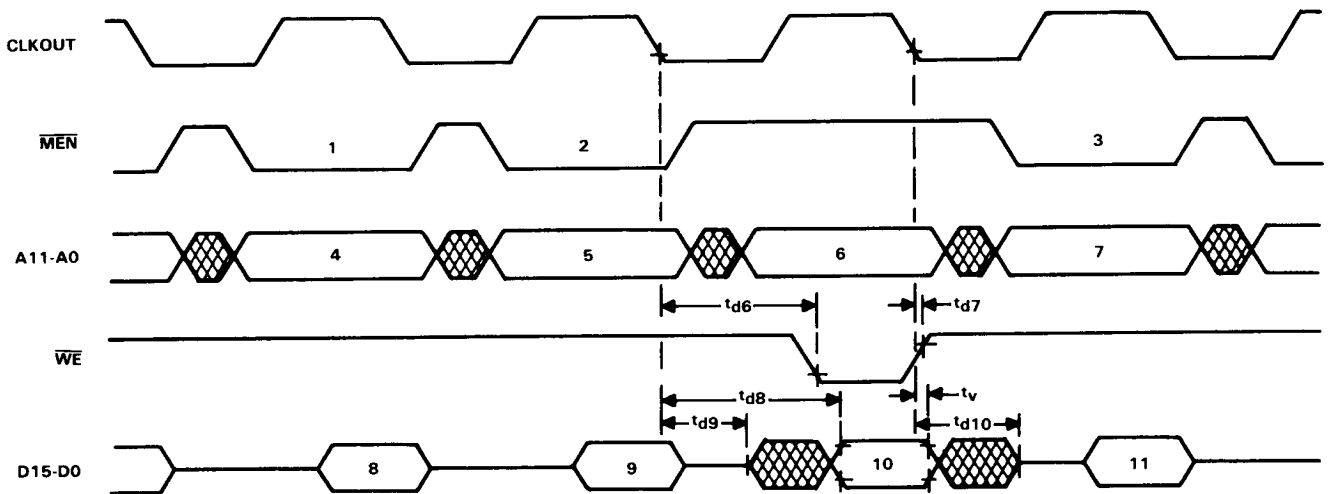

LEGEND:

- | | |
|------------------------------|--------------------------|
| 1. TBLW INSTRUCTION PREFETCH | 7. ADDRESS BUS VALID |
| 2. DUMMY PREFETCH | 8. INSTRUCTION IN VALID |
| 3. NEXT INSTRUCTION PREFETCH | 9. INSTRUCTION IN VALID |
| 4. ADDRESS BUS VALID | 10. DATA OUT VALID |
| 5. ADDRESS BUS VALID | 11. INSTRUCTION IN VALID |
| 6. ADDRESS BUS VALID | |

IN instruction timing

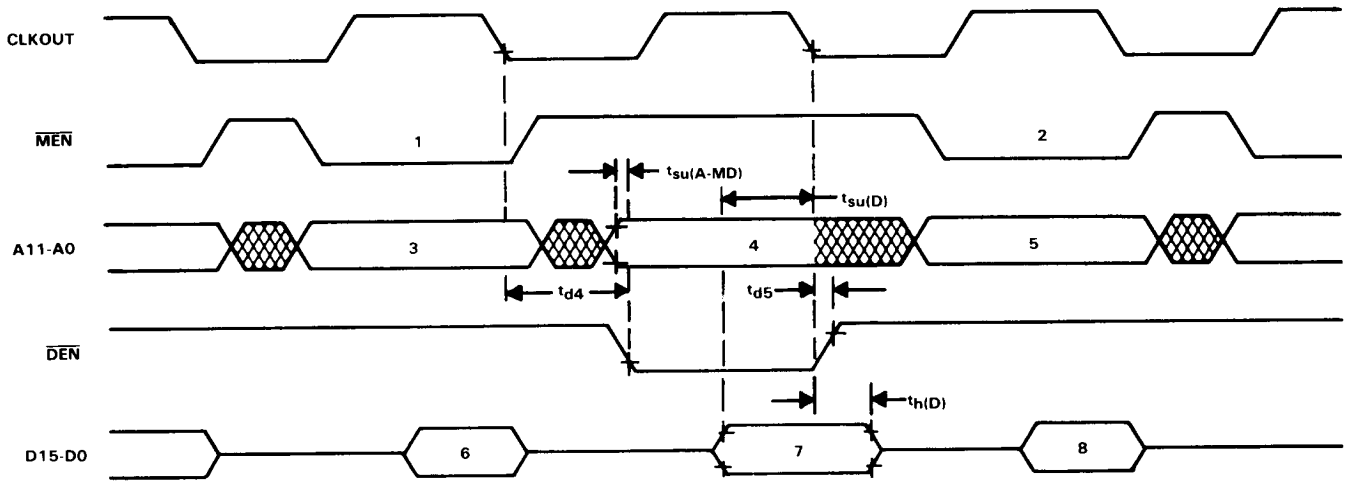

LEGEND:

- | | |
|------------------------------|-------------------------|
| 1. IN INSTRUCTION PREFETCH | 5. ADDRESS BUS VALID |
| 2. NEXT INSTRUCTION PREFETCH | 6. INSTRUCTION IN VALID |
| 3. ADDRESS BUS VALID | 7. DATA IN VALID |
| 4. PERIPHERAL ADDRESS VALID | 8. INSTRUCTION IN VALID |

OUT instruction timing

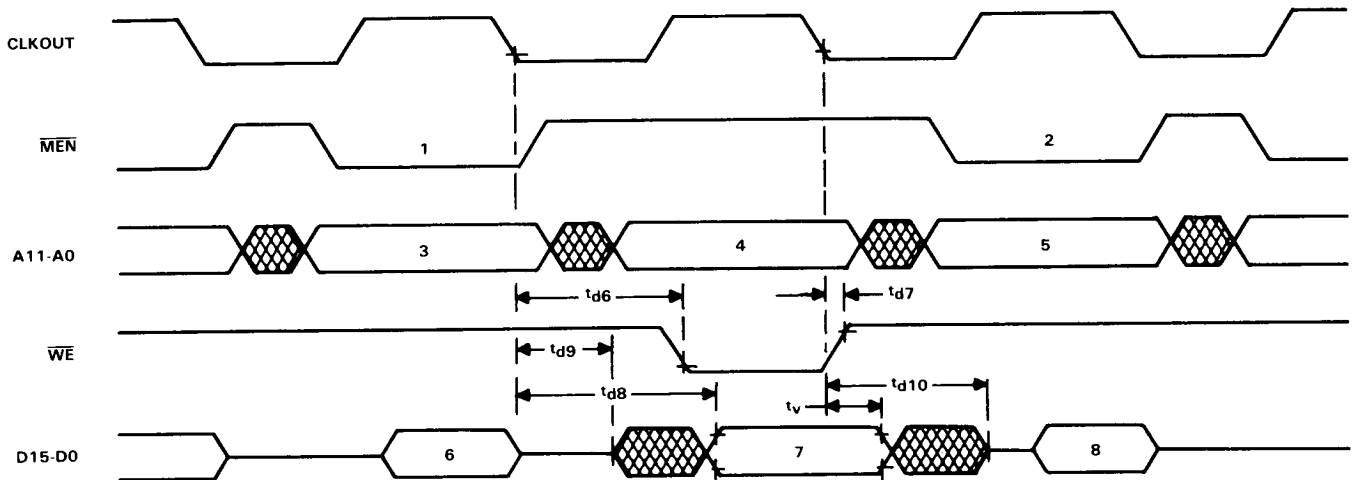

LEGEND:

- | | |
|------------------------------|-------------------------|
| 1. OUT INSTRUCTION PREFETCH | 5. ADDRESS BUS VALID |
| 2. NEXT INSTRUCTION PREFETCH | 6. INSTRUCTION IN VALID |
| 3. ADDRESS BUS VALID | 7. DATA IN VALID |
| 4. PERIPHERAL ADDRESS VALID | 8. INSTRUCTION IN VALID |

reset timing

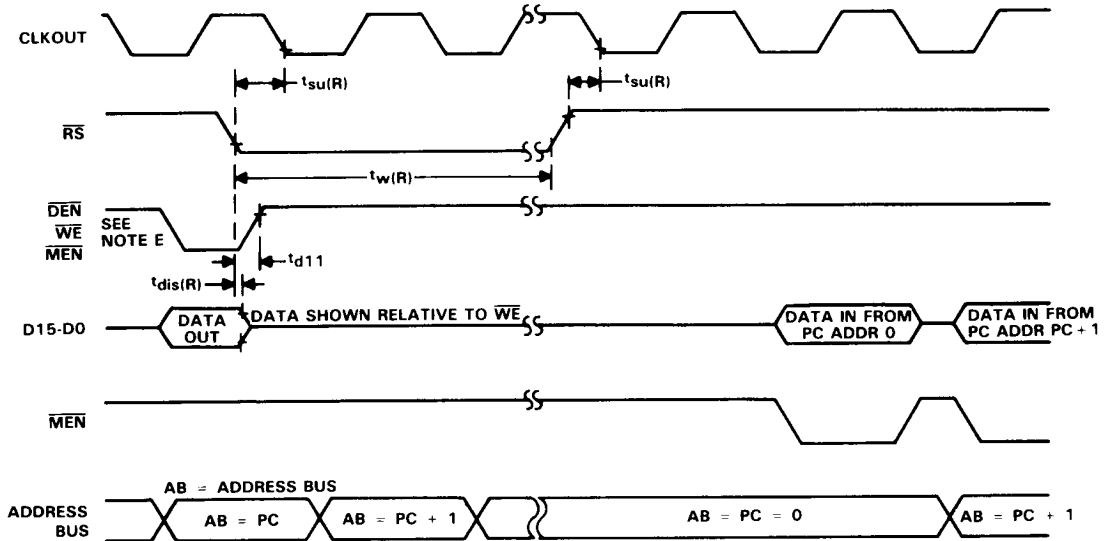

- NOTES: A. \overline{RS} forces \overline{DEN} , \overline{WE} , and \overline{MEN} high and places data bus D0 through D15 in a high-impedance state. AB outputs (and program counter) are synchronously cleared to zero after the next complete CLK cycle from $\overline{RS}\downarrow$.
- B. \overline{RS} must be maintained for a minimum of five clock cycles.
- C. Resumption of normal program will commence after one complete CLK cycle from $\overline{RS}\uparrow$.
- D. Due to the synchronizing action on \overline{RS} , time to execute the function can vary dependent upon when $\overline{RS}\uparrow$ or $\overline{RS}\downarrow$ occur in the CLK cycle.
- E. Diagram shown is for definition purpose only. \overline{DEN} , \overline{WE} , and \overline{MEN} are mutually exclusive.
- F. During a write cycle, \overline{RS} may produce an invalid write address.

interrupt timing

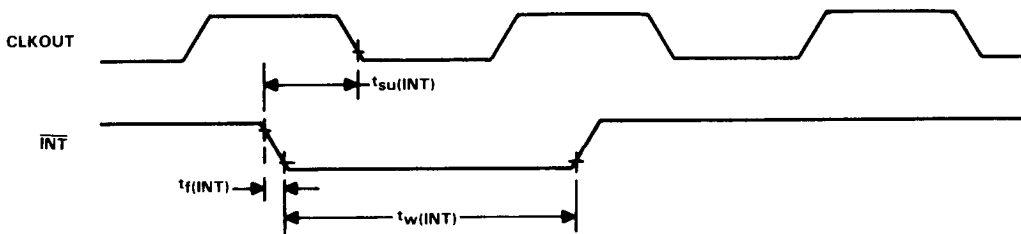

BIO timing

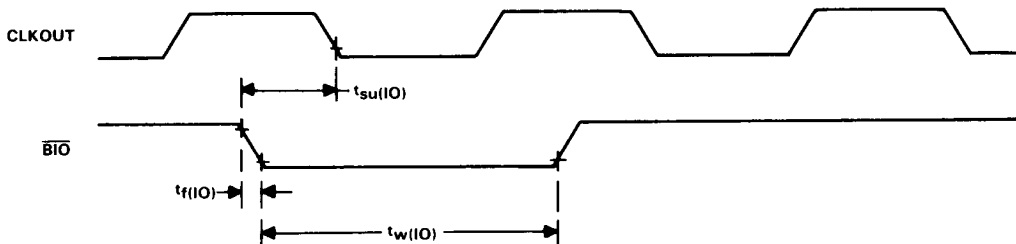

reset timing

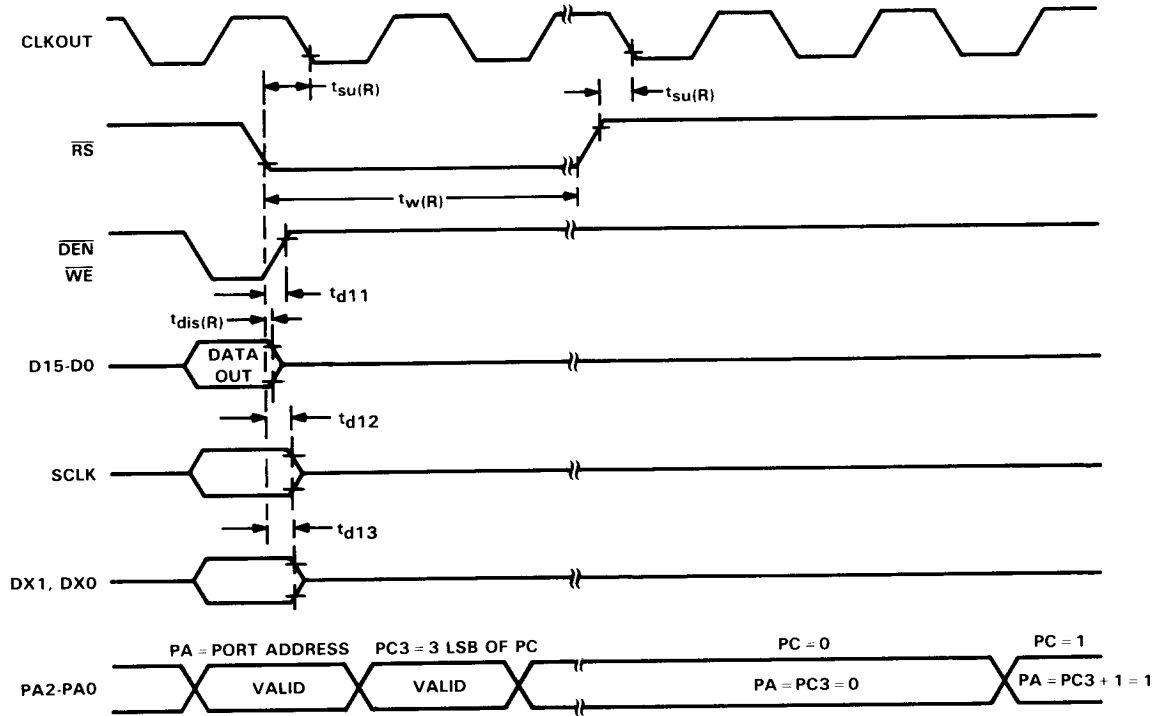

interrupt timing

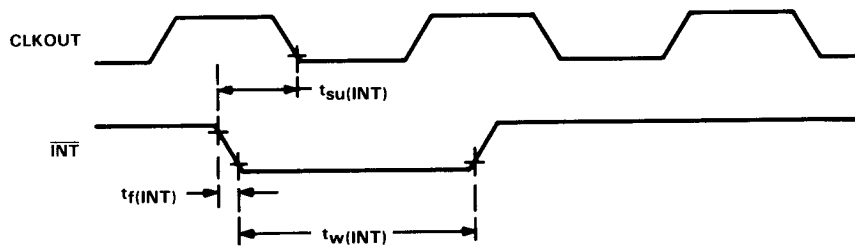

BIO timing

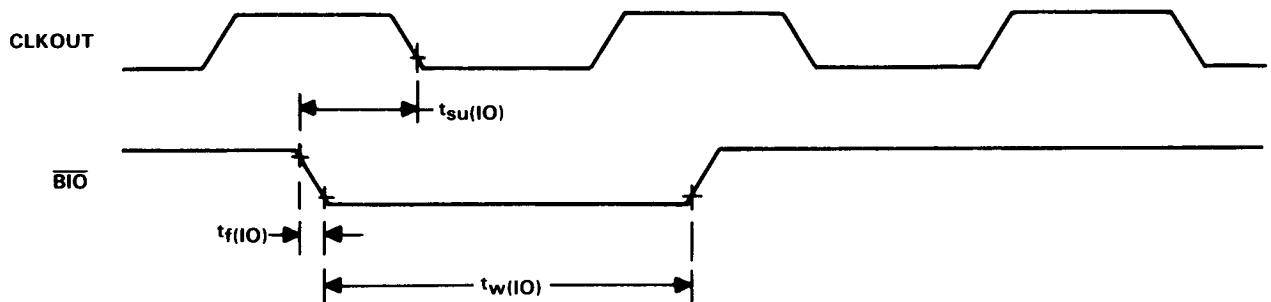

BIO timing (peripheral mode on TMS32011 only)

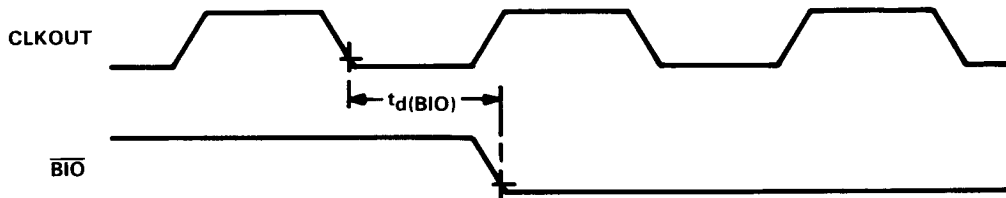

XF timing

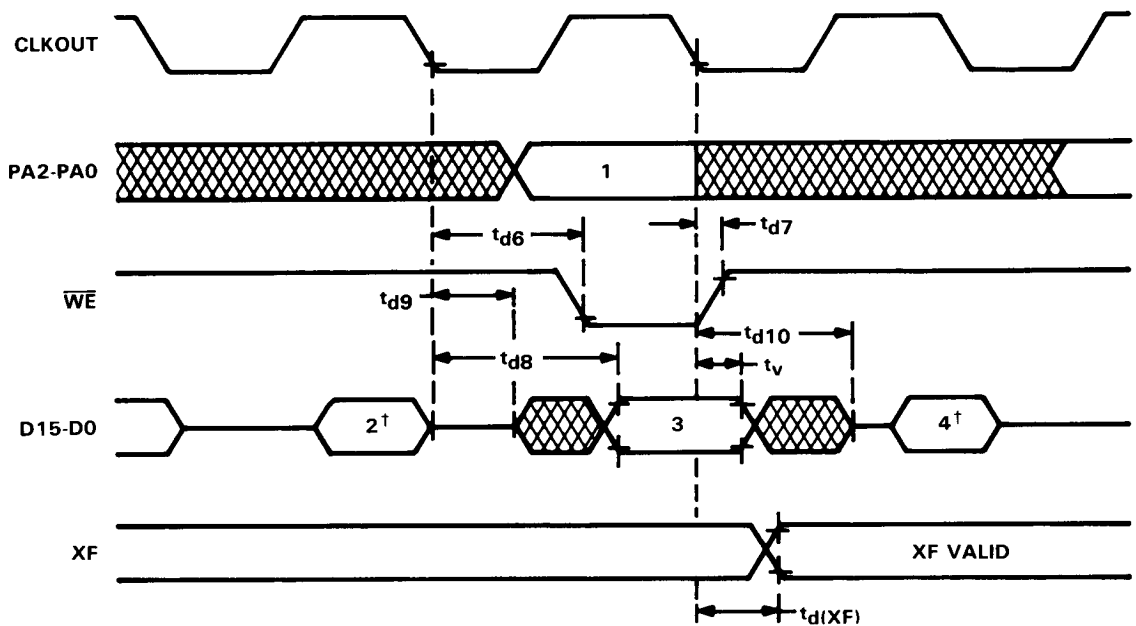

LEGEND:

- | | |
|-----------------------|-----------------------------------|
| 1. PORT ADDRESS VALID | 3. PORT DATA VALID |
| 2. OUT OP CODE VALID | 4. NEXT INSTRUCTION OP CODE VALID |

external framing: transmit timing

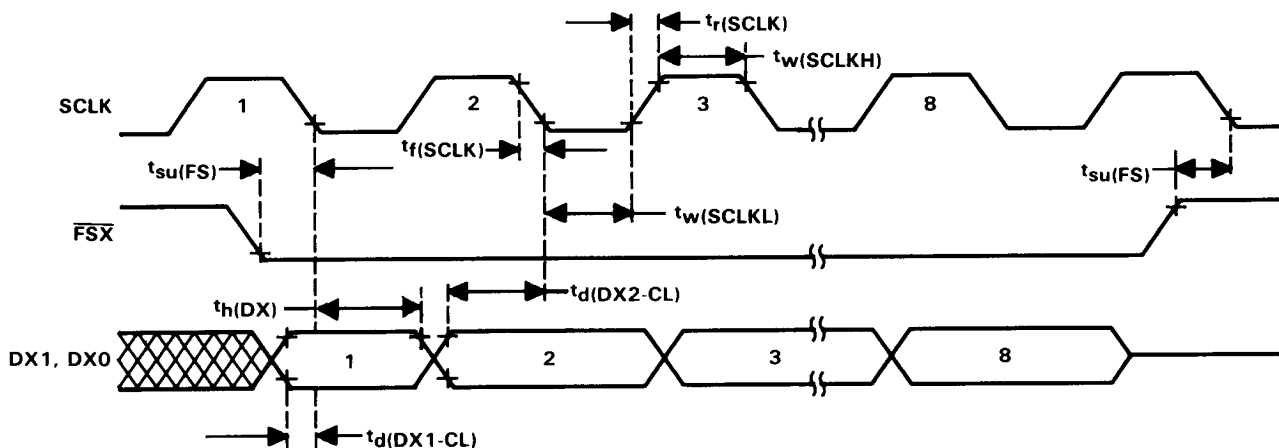

NOTES: G. Data valid on transmit outputs until SCLK rises.
H. The most significant bit is shifted first.

external framing: receive timing

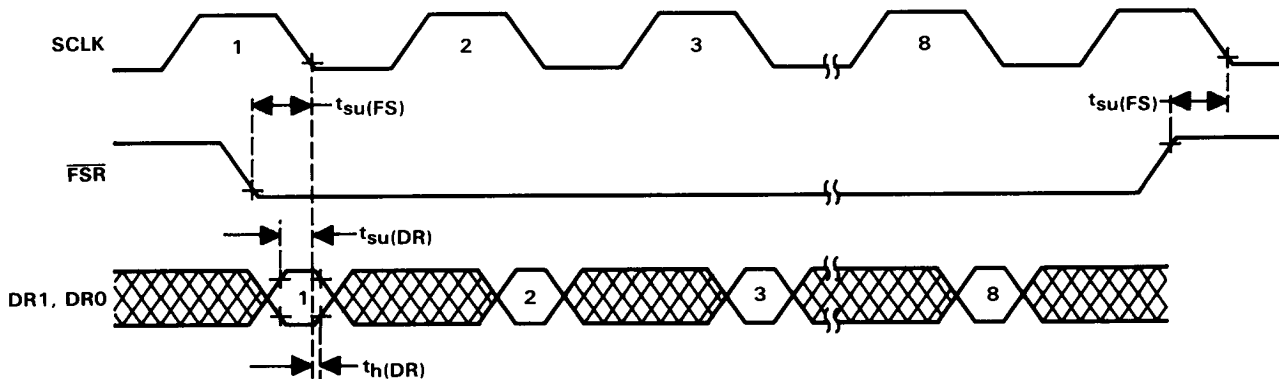

NOTE H: The most significant bit is shifted first.

internal framing: variable-data rate

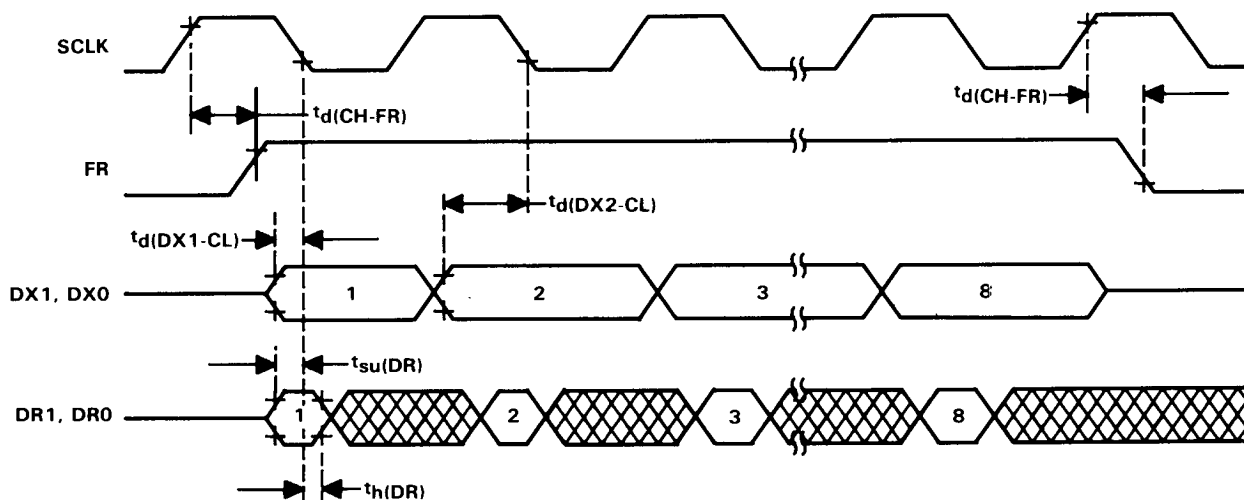

NOTE H: The most significant bit is shifted first.

internal framing: fixed-data rate

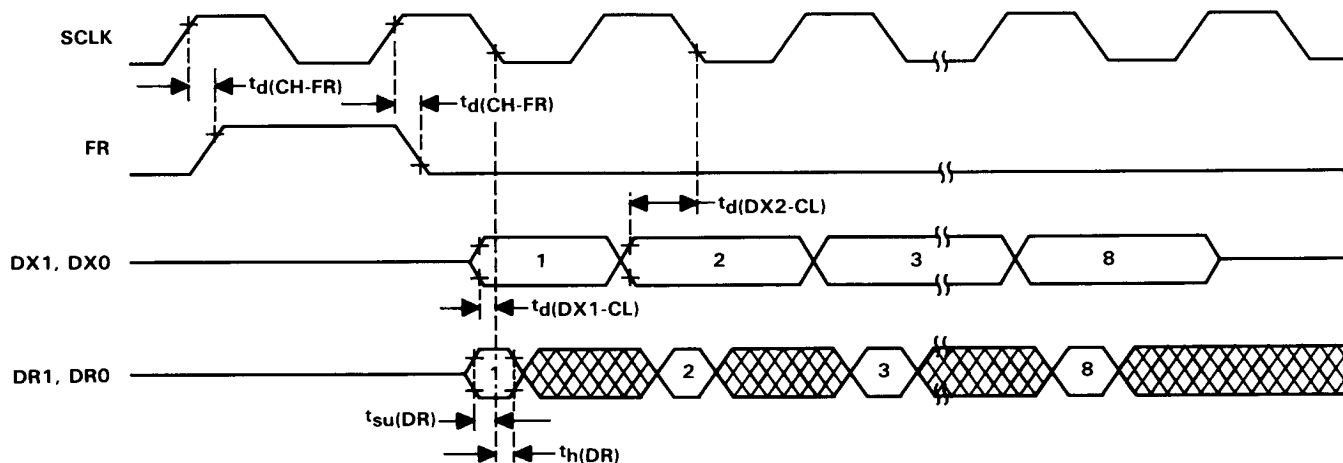

NOTE H: The most significant bit is shifted first.

coprocessor timing: external write to coprocessor port

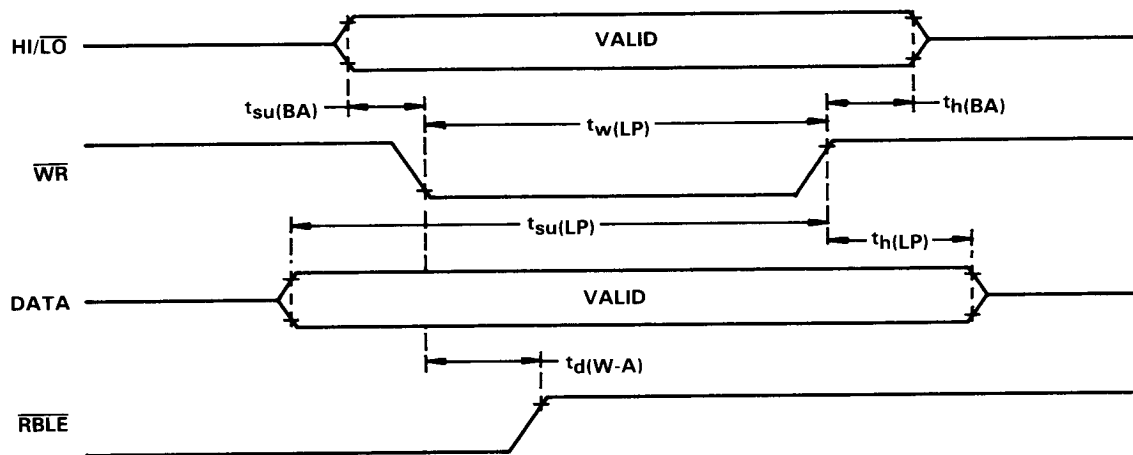

coprocessor timing: external read from coprocessor port

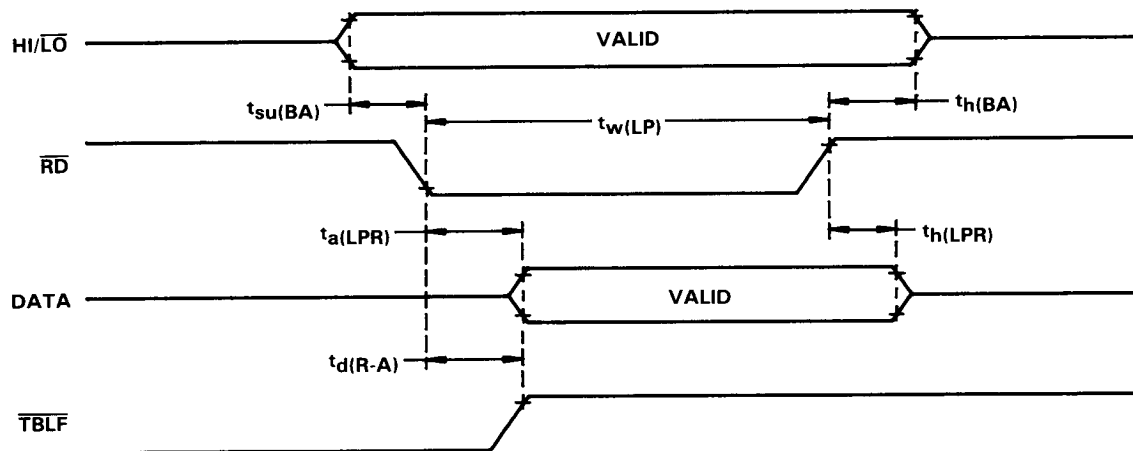



EPROM PROGRAMMING

absolute maximum ratings over specified temperature range (unless otherwise noted)[†]

Supply voltage range, V_{pp} (see Note 1) -0.6 V to 14 V

[†]Stresses beyond those listed under "Absolute Maximum Ratings" may cause permanent damage to the device. This is a stress rating only and functional operation of the device at these or any other conditions beyond those indicated in the "Recommended Operating Conditions" section of this specification is not implied. Exposure to absolute-maximum-rated conditions for extended periods may affect device reliability.

NOTE 1. All voltage values are with respect to GND.

recommended operating conditions

	MIN	NOM	MAX	UNIT
V_{pp} Supply voltage (see Note 2)	0	12	12.5	V

NOTE 2: V_{pp} can be connected to V_{CC} directly (except in the program mode). V_{CC} supply current in this case would be $I_{CC} + I_{pp}$. During programming, V_{pp} must be maintained at 12.5 V (± 0.5 V).

electrical characteristics over specified temperature range (unless otherwise noted)

PARAMETER	TEST CONDITIONS	MIN	TYP [†]	MAX	UNIT
I_{PP1} V_{pp} supply current	$V_{pp} = V_{CC} = 5.25$ V			100	μ A
I_{PP2} V_{pp} supply current (during program pulse)	$V_{pp} = 13$ V		30	50	mA

[†]All typical values except for I_{CC} are at $V_{CC} = 5$ V, $T_A = 25^\circ\text{C}$.

recommended timing requirements for programming, $T_A = 25^\circ\text{C}$, $V_{CC} = 6$ V, $V_{pp} = 12.5$ V (see Note 3)

	MIN	NOM	MAX	UNIT
$t_{w(IPGM)}$ Initial program pulse duration	0.95	1	1.05	ms
$t_{w(FPGM)}$ Final pulse duration	2.85		78.75	ms
$t_{su(A)}$ Address setup time	2			μ s
$t_{su(E)}$ \bar{E} setup time	2			μ s
$t_{su(G)}$ \bar{G} setup time	2			μ s
$t_{dis(G)}$ Output disable time from \bar{G}	0		130	ns
$t_{en(G)}$ Output enable time from \bar{G}			150	ns
$t_{su(D)}$ Data setup time	2			μ s
$t_{su(V_{pp})}$ V_{pp} setup time	2			μ s
$t_{su(V_{CC})}$ V_{CC} setup time	2			μ s
$t_h(A)$ Address hold time	0			μ s
$t_h(D)$ Data hold time	2			μ s

NOTES 3. For all switching characteristics and timing measurements, input pulse levels are 0.40 V to 2.4 V and $V_{pp} = 12.5$ V ± 0.5 V during programming.

4. Common test conditions apply for $t_{dis(G)}$ except during programming.



POST OFFICE BOX 1443 • HOUSTON, TEXAS 77001

PROGRAMMING THE TMS320E15/E17 EPROM CELL

The TMS320E15/E17 includes a 4K x 16-bit industry-standard EPROM cell for prototyping, early field testing, and low-volume production. The TMS320C15/C17 with a 4K-word masked ROM then provides a migration path for cost-effective production. An EPROM programmer adaptor socket (part # RTC/PGM320A-06), shown in Figure 7, is available to provide 40-pin to 28-pin conversion for programming the TMS320E15/E17.

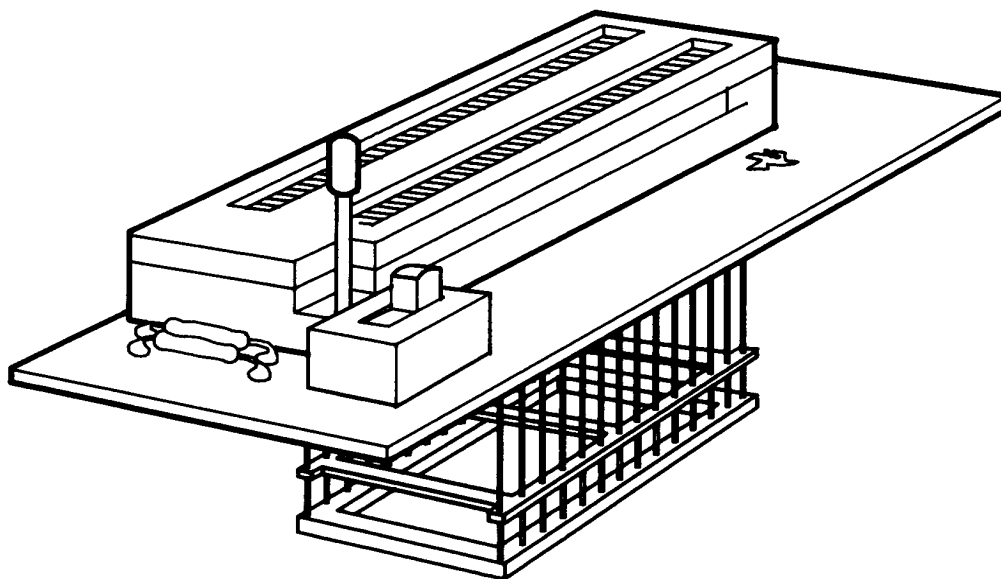
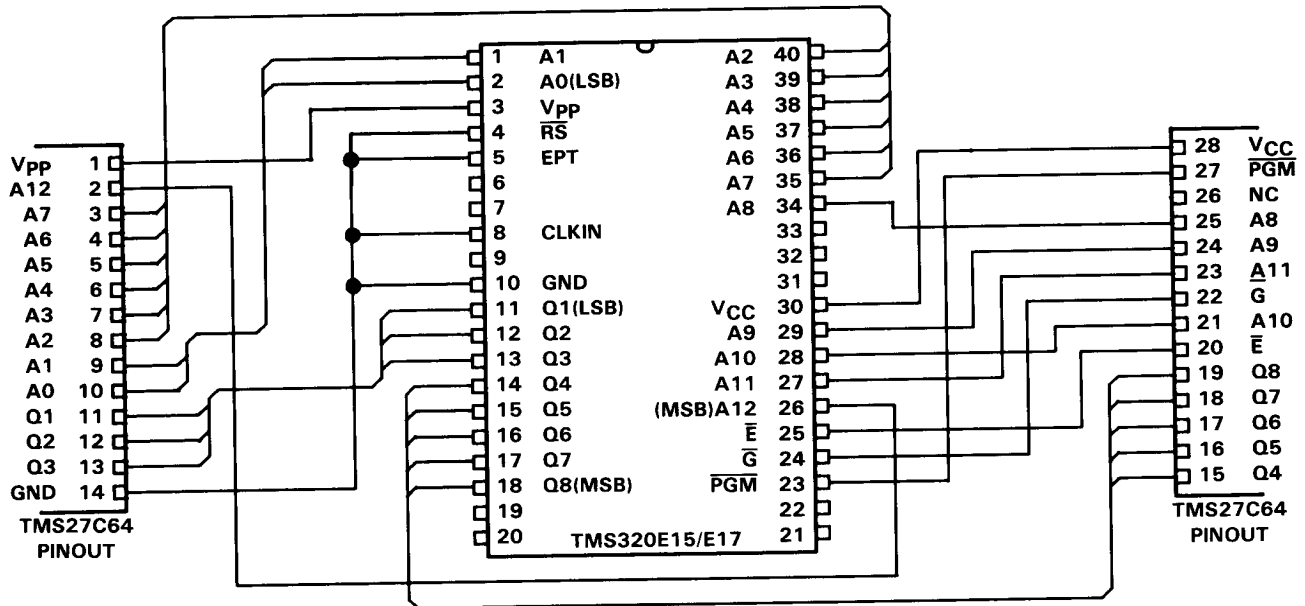

FIGURE 7. EPROM PROGRAMMER ADAPTOR SOCKET

Key features of the EPROM cell include the normal programming operation as well as verification. The EPROM cell also includes a code protection feature that allows code to be protected against copyright violations.

The TMS320E15/E17 EPROM cell is programmed using the same family and device pinout codes as the TMS27C64 8K x 8-bit EPROM. The TMS27C64 EPROM series are ultraviolet-light erasable, electrically programmable, read-only memories, fabricated using HVC MOS technology. They are pin-compatible with existing 28-pin ROMs and EPROMs. These EPROMs operate from a single 5-V supply in the read mode; however, 12.5-V V_{pp} and 6-V V_{CC} supplies are needed for programming. All programming signals are TTL level. For programming outside the system, existing EPROM programmers can be used. Locations may be programmed singly, in blocks, or at random.

Figure 8 shows the wiring conversion to program the TMS320E15/E17 using the 28-pin pinout of the TMS27C64. The table of pin nomenclature provides a description of the TMS27C64 pins. The code to be programmed into the device should be in serial mode. The TMS320E15/E17 uses 13 address lines to address the 4K-word memory in byte format.



PIN NOMENCLATURE (TMS320E15/TMS320E17)

NAME	I/O	DEFINITION
A12(MSB)-A0(LSB)	I	On-chip EPROM programming address lines
CLKIN	I	Clock oscillator input
\bar{E}	I	EPROM chip select
EPT	I	EPROM test mode select
\bar{G}	I	EPROM read/verify select
GND	I	Ground
\overline{PGM}	I	EPROM write/program select
Q8(MSB)-Q1(LSB)	I/O	Data lines for byte-wide programming of on-chip 8K bytes of EPROM
\bar{RS}	I	Reset for initializing the device
VCC	I	5-V power supply
Vpp	I	12.5-V power supply

FIGURE 8. TMS320E15/E17 EPROM PROGRAMMING CONVERSION TO TMS27C64 EPROM PINOUT

Table 8 shows the programming levels required for programming, verifying, reading, and protecting the EPROM cell.

TABLE 8. TMS320E15/E17 PROGRAMMING MODE LEVELS

SIGNAL NAME	TMS320E15/E17 PIN	TMS27C64 PIN	PROGRAM	VERIFY	READ	PROTECT VERIFY	ROM PROTECT
\bar{E}	25	20	V _{IL}	V _{IL}	V _{IL}	V _{IL}	V _{IH}
\bar{G}	24	22	V _{IH}	PULSE	PULSE	V _{IL}	V _{IH}
$\bar{P}GM$	23	27	PULSE	V _{IH}	V _{IH}	V _{IH}	V _{IH}
V _{PP}	3	1	V _{PP}	V _{PP}	V _{CC}	V _{CC}	V _{PP}
V _{CC}	30	28	V _{CC}	V _{CC}	V _{CC}	V _{CC}	V _{CC}
V _{SS}	10	14	V _{SS}	V _{SS}	V _{SS}	V _{SS}	V _{SS}
CLKIN	8	14	V _{SS}	V _{SS}	V _{SS}	V _{SS}	V _{SS}
$\bar{R}S$	4	14	V _{SS}	V _{SS}	V _{SS}	V _{SS}	V _{SS}
EPT	5	26	V _{SS}	V _{SS}	V _{SS}	V _{PP}	V _{PP}
Q8-Q1	18-11	19-15, 13-11	D _{IN}	Q _{OUT}	Q _{OUT}	Q8 = RBIT	V _{IL}
A12-A10	26-28	2,23,21	ADDR	ADDR	ADDR	X	X
A9-A7	29,34,35	24,25,3	ADDR	ADDR	ADDR	X	X
A6	36	4	ADDR	ADDR	ADDR	V _{IL}	X
A5	37	5	ADDR	ADDR	ADDR	X	X
A4	38	6	ADDR	ADDR	ADDR	X	V _{IH}
A3-A0	39,40,1,2	7-10	ADDR	ADDR	ADDR	X	X

LEGEND:

V_{IH} = TTL high level; V_{IL} = TTL low level; ADDR = byte address bit
V_{PP} = 12.5 V ±0.5 V; V_{CC} = 5 V ±5% for read only, otherwise, V_{CC} = 6 V; X = don't care
PULSE = low-going TTL level pulse; D_{IN} = byte to be programmed at ADDR
Q_{OUT} = byte stored at ADDR; RBIT = ROM protect bit.

programming

Since every memory bit in the cell is a logic 1, the programming operation reprograms certain bits to 0. Once programmed, these bits can only be erased using ultraviolet light. The correct byte is placed on the data bus with V_{PP} set to the 12.5-V level. The $\bar{P}GM$ pin is then pulsed low to program in the zeroes.

erasure

Before programming, the device must be erased by exposing it to ultraviolet light. The recommended minimum exposure dose (UV-intensity X exposure-time) is 15 watt-seconds per square centimeter. A typical 12 milliwatt-seconds per square centimeter, filterless UV lamp will erase the device in 21 minutes. The lamp should be located about 2.5 centimeters above the chip during erasure. After exposure, all bits are in the high state.

verify/read

To verify correct programming, the EPROM cell can be read using either the verify or read line definitions shown in Table 8, assuming the inhibit bit has not been programmed.

program inhibit

To protect the proprietary algorithms existing in the code programmed on-chip, the ability to read or verify code from external accesses can be completely disabled. Programming the RBIT disables external access of the EPROM cell and disables the microprocessor mode, making it impossible to access the code resident in the EPROM cell. The only way to remove this protection is to erase the entire EPROM cell, thus removing the proprietary information. The signal requirements for programming this bit are shown in Table 8. The cell can be determined as protected by verifying the programming of the RBIT shown in the table.

standard programming procedure

Before programming, the device must first be completely erased. Then the device can be programmed with the correct code. It is advisable to program unused sections with zeroes as a further security measure. After the programming is complete, the code programmed into the cell should be verified. If the cell passes verification, the next step is to program the ROM protect bit (RBIT). Once the RBIT programming is verified, an opaque label should be placed over the window to protect the EPROM cell from inadvertent erasure by ambient light. At this point, the programming is complete, and the device is ready to be placed into its destination circuit.

program cycle timing

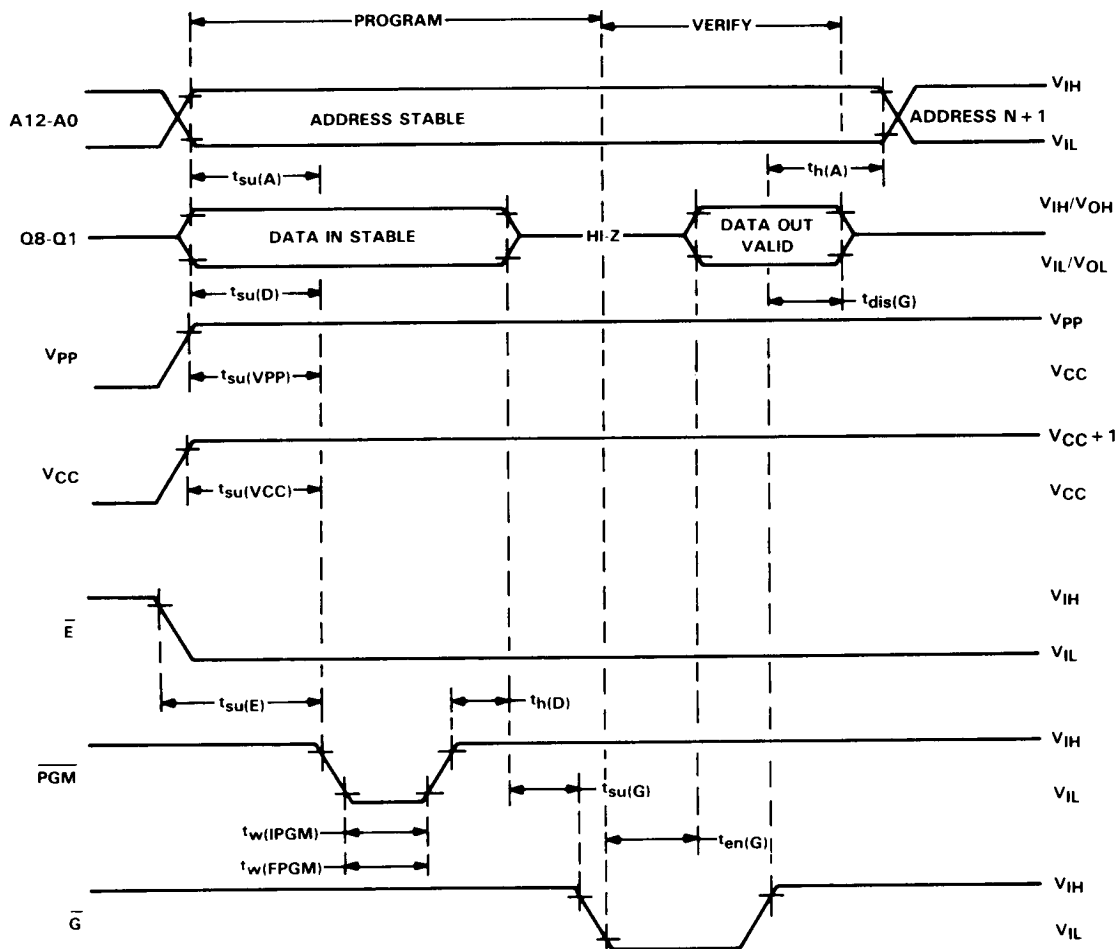

TYPICAL POWER VS. FREQUENCY GRAPHS

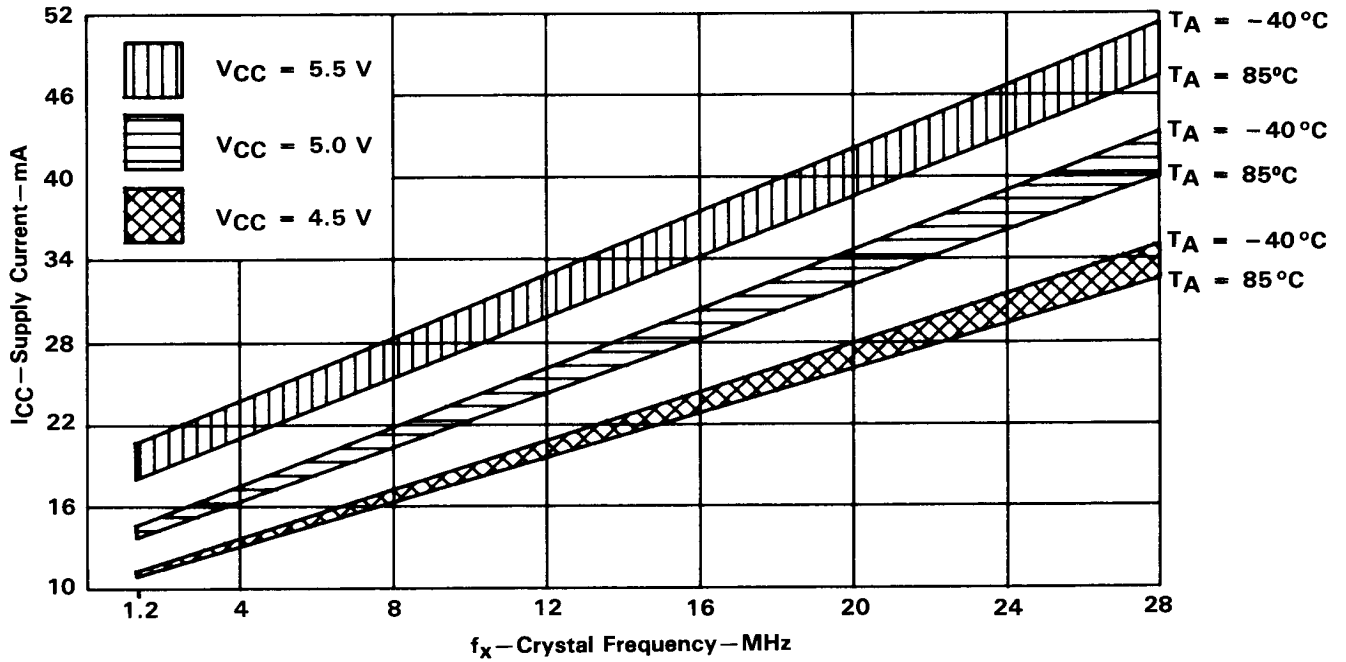

(a) -40°C TO 85°C TEMPERATURE RANGE

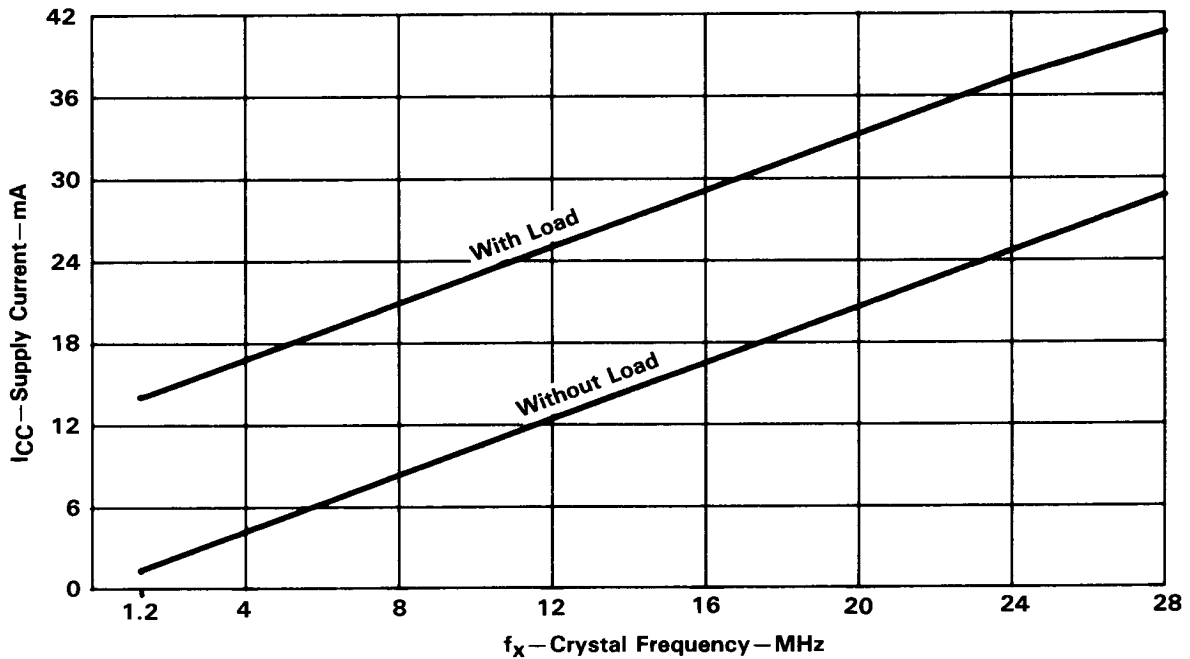

(b) VOLTAGE = 5 V; TEMPERATURE = 25°C

FIGURE 9. TYPICAL CMOS ICC VS. FREQUENCY

PACKAGE TYPES

PACKAGE TYPE	SUFFIX	FAMILY MEMBERS
40-pin plastic DIP (100-mil pin spacing)	N	NMOS: TMS32010, TMS32010-25, TMS32010-14, TMS32011 CMOS: TMS320C10, TMS320C10-25, TMS320C15 [†] , TMS320C15-25 [†] , TMS320C17 [†] , TMS320C17-25 [†]
44-lead PLCC (50-mil pin spacing)	FN	CMOS: TMS320C10, TMS320C10-25 [†] , TMS320C15 [†] , TMS320C15-25 [†] , TMS320C17 [†] , TMS320C17-25 [†]
40-pin windowed ceramic DIP	JD	CMOS: TMS320E15, TMS320E17

[†]Planned versions; contact TI representative for availability.

THERMAL DATA

thermal resistance characteristics

PACKAGE	R _{θJA} (°C/W)	R _{θJC} (°C/W)
40-pin plastic dual-in-line package (NMOS [†])	51.6	16.6
40-pin plastic dual-in-line package (CMOS)	84	26
40-pin windowed ceramic dual-in-line package (CMOS)	41	8
44-lead plastic chip carrier package (CMOS)	60	17

[†]A more thermally efficient package has been used to compensate for higher power dissipation of the NMOS part.

TMS320 FIRST-GENERATION DEVICES

MECHANICAL DATA

40-pin plastic dual-in-line package

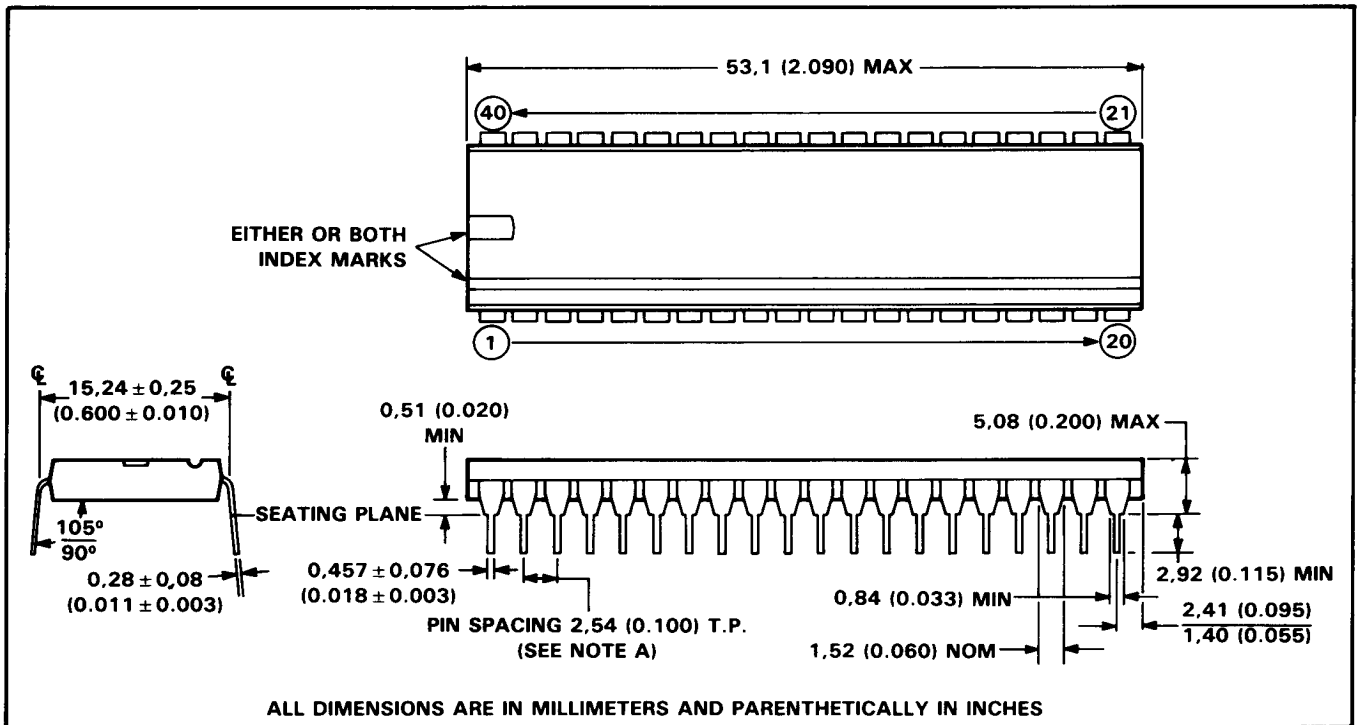

NOTE A: Each pin centerline is located within 0,254 (0.010) of its true longitudinal position.

40-pin windowed ceramic dual-in-line package (TMS320E15/E17)

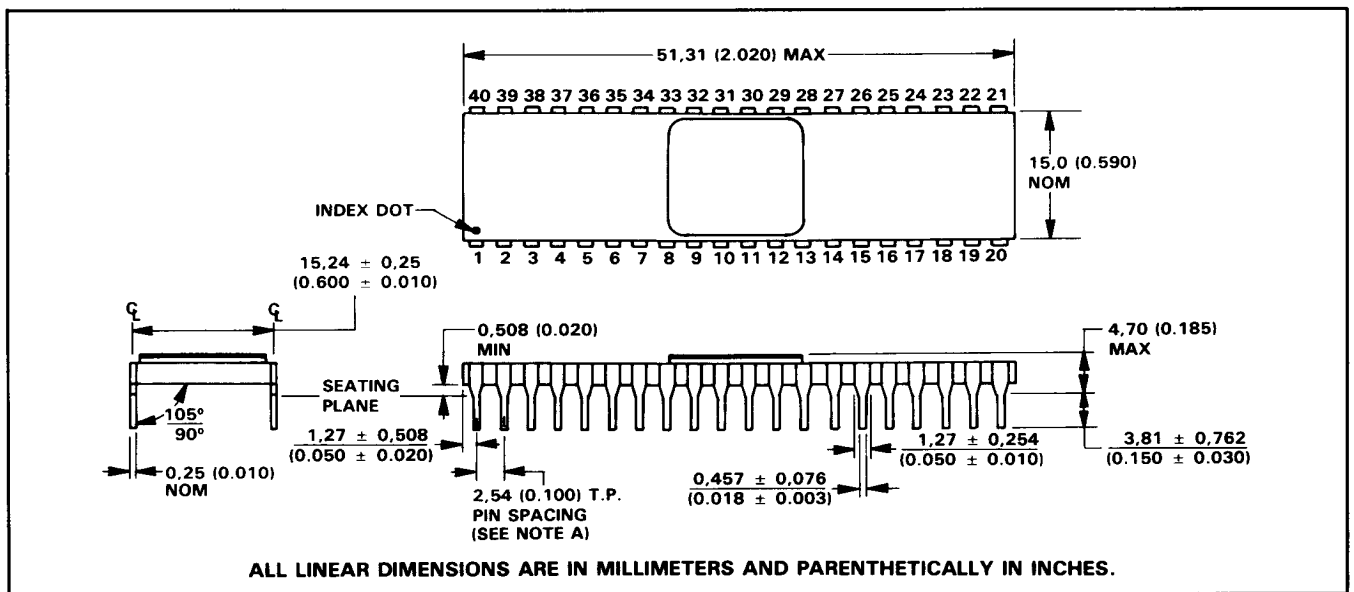

NOTE A: Each pin centerline is located within 0,254 (0.010) of its true longitudinal position.

44-lead plastic chip carrier package

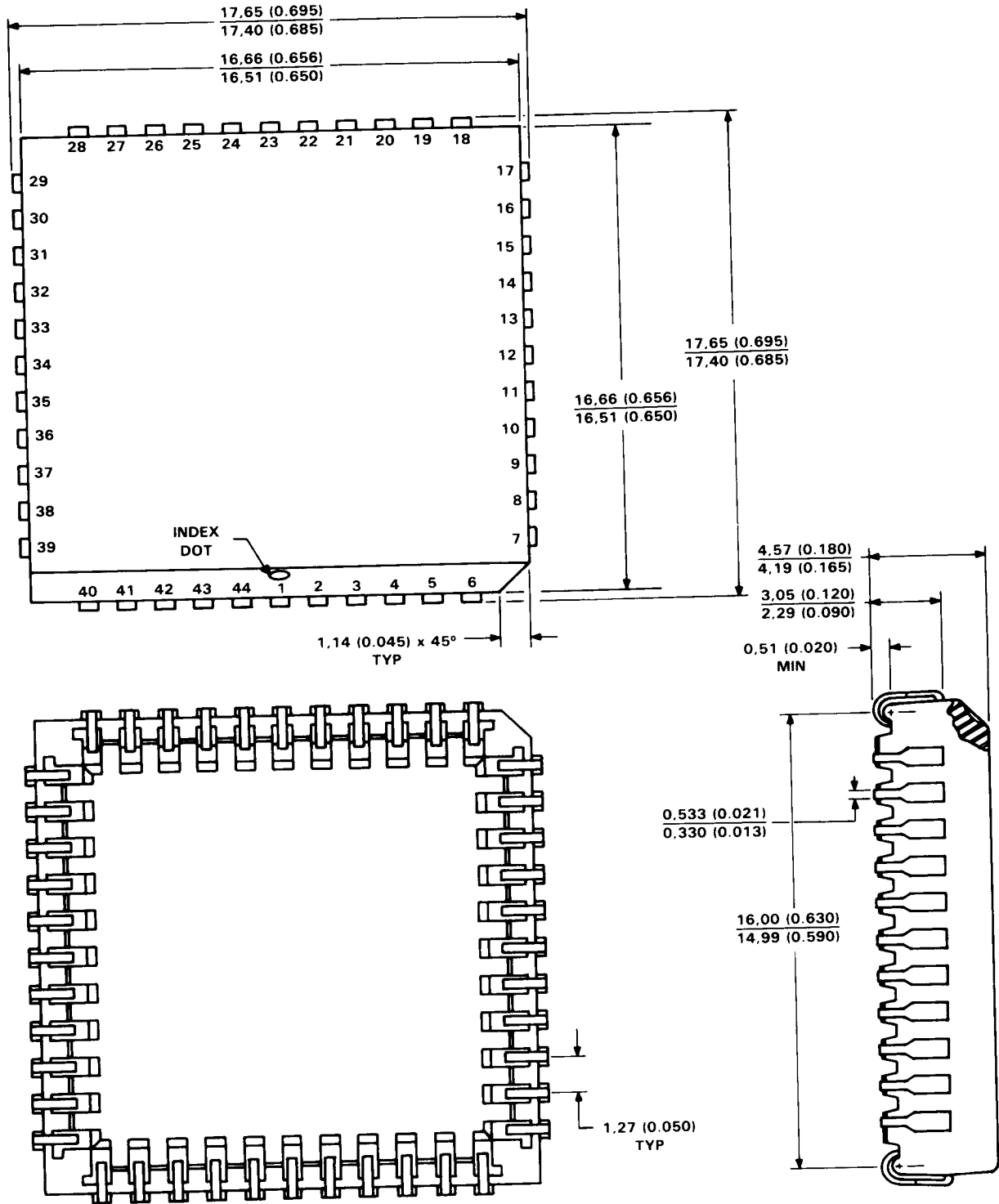

ALL DIMENSIONS ARE IN MILLIMETERS AND PARENTHETICALLY IN INCHES

INDEX

accumulator	6	instruction set	8-11
ALU	6	interrupts	7, 17, 22
architecture		I/O channels	7, 17, 22
TMS32010/C10/C15/E15	6, 7	key features	
TMS32011	6, 7, 17-19	TMS32010/C10	4
TMS320C17/E17	6, 7, 20-25	TMS32011	5
block diagram		TMS320C15/E15	4
TMS32010/C10/C15/E15	4, 14	TMS320C17/E17	5
TMS32011	3, 16	mechanical data	68, 69
TMS320C17/E17	5, 21	memory	
codec interface	19, 24	TMS32010/C10	6
companding hardware		TMS32011	6
TMS32011	7, 17, 19	TMS320C15/E15	6
TMS320C17/E17	7, 22	TMS320C17/E17	6
control register		microcomputer/microprocessor mode	7
TMS32011	17-19	microcomputer/coprocessor mode	7
TMS320C17/E17	22, 23	multiplier	6
coprocessor interface	7, 24, 25	package types	67
description		pinout/nomenclature	
TMS32010/C10/C15/E15	2, 13	TMS32010/C10/C15/E15	13
TMS32011	2, 15	TMS32011	15
TMS320C17/E17	3, 20	TMS320C17/E17	20
development support products	11, 12	power vs. frequency graphs	66
documentation support	12	program memory expansion	6
electrical specifications		serial port	
TMS32010	27-34	TMS32011	7, 17
TMS32011	27, 28, 35-38	TMS320C17/E17	7, 22
TMS320C10	39-43	shifters	6
TMS320C15/E15	39, 40, 44-46	subroutines	7
TMS320C17/E17	39, 40, 47-50	thermal data	67
EPROM		timer	7, 17, 22
TMS320E15/E17	6, 62	timing diagrams	
EPROM adaptor socket	62	TMS32010/C10/C15/E15	51-54
EPROM programming		TMS32011	51-53, 55-58
TMS320E15/E17	61-65	TMS320C17/E17	51-53, 55-59
framing pulses			
TMS32011	7, 17		
TMS320C17/E17	7, 22		